

The Panel N65 – High bearing capacity and less roof pitch

Excellence in Manufacturing Technology

While the BEMO Mobile Mill Factories are transportable, they are light years beyond being “portable” roll formers. The German Engineered mills are comprised of state-of-the-art roll forming technology utilizing a minimum of twelve (12) rolling stations for the forming process. These 20 ton mills utilize an ocean going container as their platform for operation and would be equally at home on any manufacturing floor.

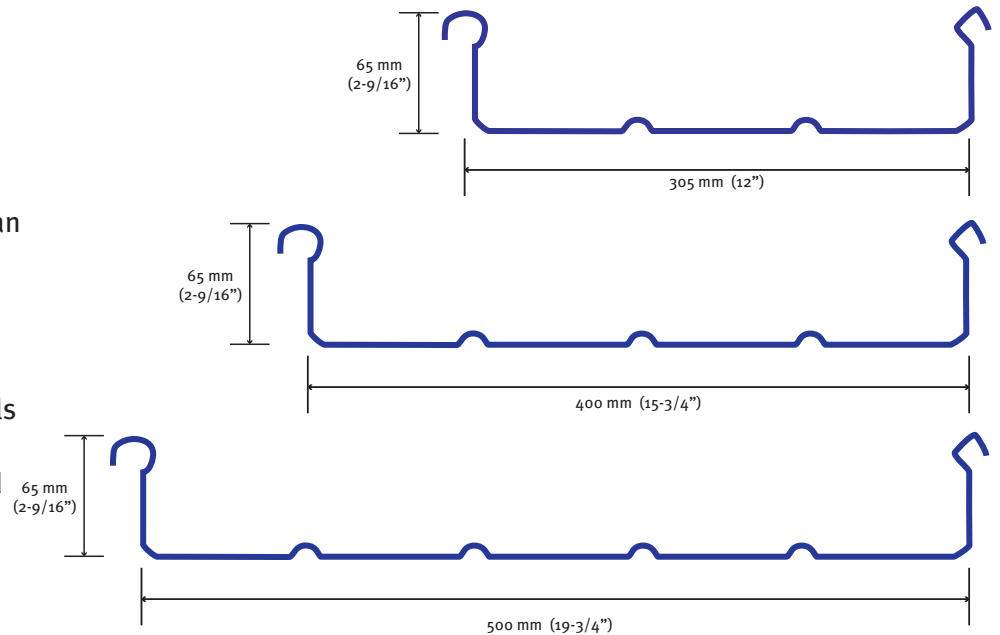

Specifications

| | |
|-------------------|--|
| Panel width: | 305 mm, 400 mm, 500 mm |
| Variable panels: | 100 mm to 682 mm |
| Rib: | parallel to panel curvature, centered and straight |
| Capillary groove: | integrated into all panels |

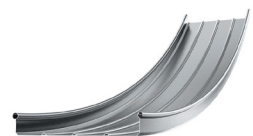
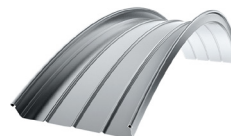
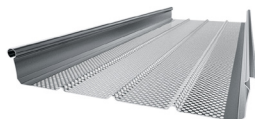
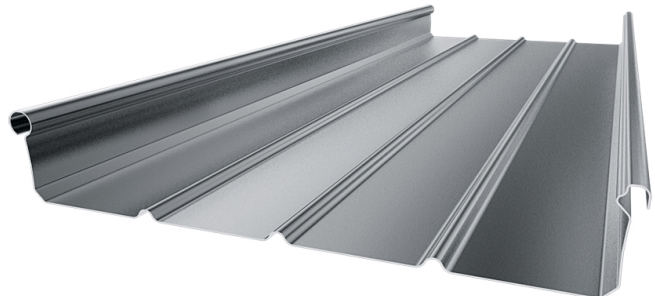

Bemo USA Corporation

1755 N. 48th Street, Mesa, Arizona USA 85205 | 480-545-7900

visit www.bemousa.com. For more information call or email at techservices@bemousa.com.