

- NOTES:**
1. SYSTEM INSTALLS BOTTOM TO TOP, LEFT TO RIGHT.
 2. ACTUAL DIMENSIONS FOR ACCURE WALL PANELS TO BE DETERMINED IN FIELD.
 3. FRAMING SHOWN IS AN EXAMPLE ONLY. ACTUAL SUPPORT TO BE VERIFIED IN FIELD.
 4. ALL FASTENERS MUST PENETRATE 3/4" MIN. THROUGH SUBSTRATE AND FRAMING.

THIS DETAIL IS GENERAL IN NATURE AND WILL BE MODIFIED TO MEET JOB SPECIFIC CONDITIONS

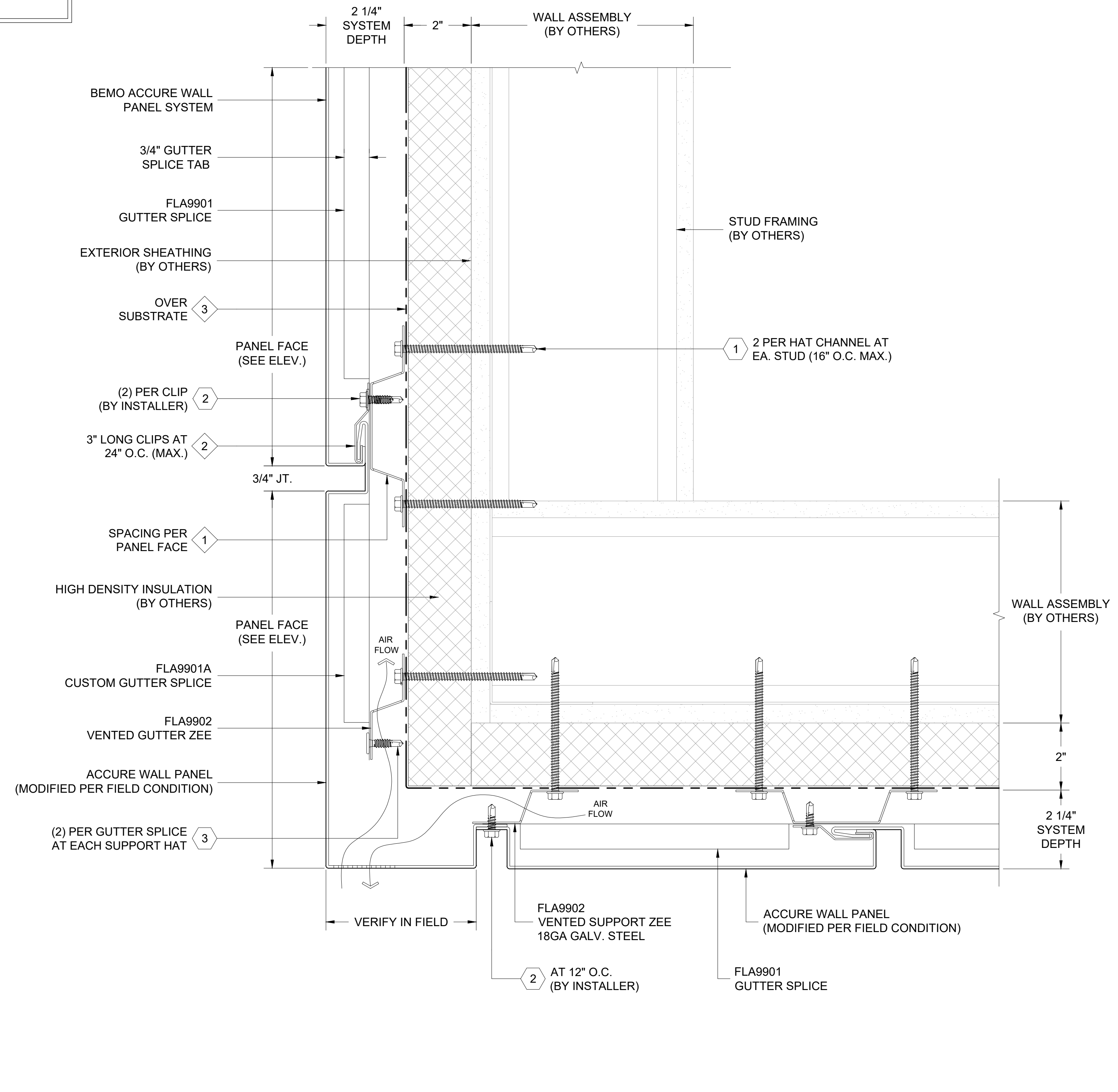
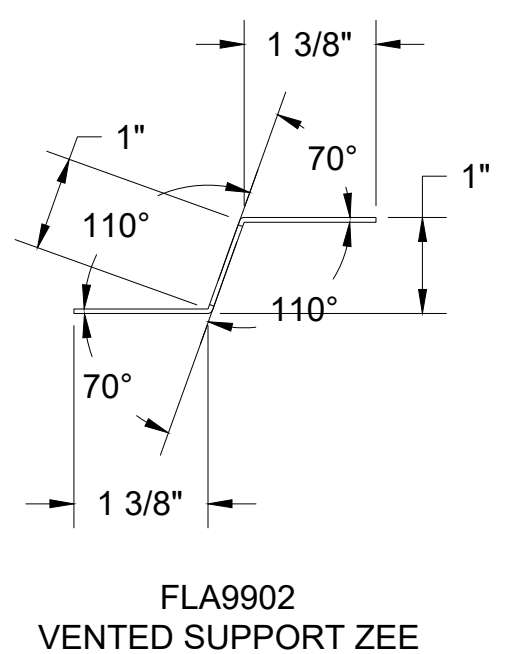
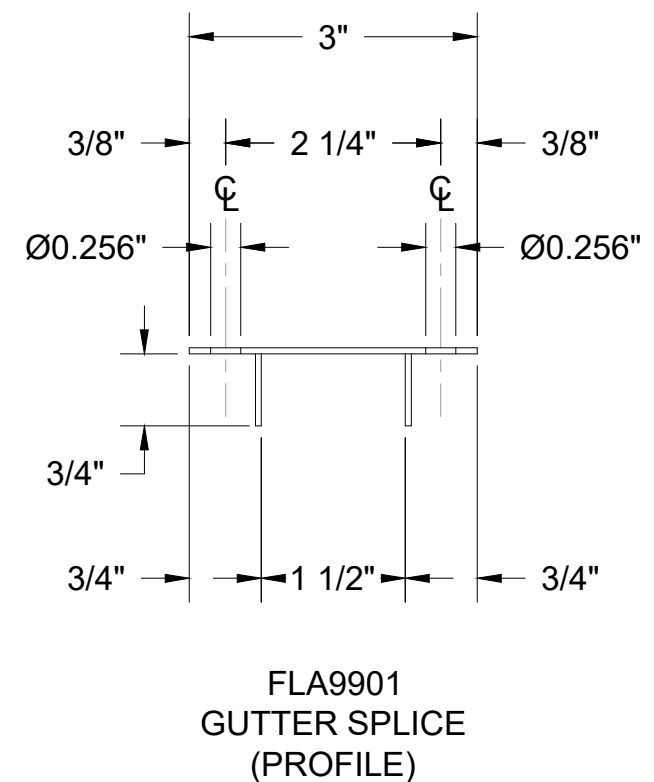

1 SOFFIT AT FASCIA DETAIL
D1 REF. ARCH. DET. -

FASTENER DESIGNATIONS

MARK	DESCRIPTION	IMAGE
1	1/4"-14 x 2 1/2" HWH DP3 TEK SCREW - (BY OTHERS)	
2	1/4"-14 x 3/4" HWH DP3 TEK SCREW (OR COMPARABLE)	
3	1/4"-14 x 1" #3PT PANCAKE HEAD SCREW	
4	3/16" POP RIVET	

* (1000 HRS OF CORROSION RESISTANT COATING IN ACCORDANCE WITH ASTM B117)

MATERIAL DESIGNATIONS

MARK	DESCRIPTION
1	STRFH54 VENTED 1" DEEP HAT CHANNEL (18 GA. GALV. STEEL)
2	BEMO 20GA ACCURE PANEL ATTACHMENT CLIP (3" LONG AT 24" O.C. MAX)
3	BEMO "BLOCKSHIELD PLUS" (60" x 100' LONG ROLLS)
4	APPROVED SEALANT (15LF COVERAGE - TUBES) - (BY OTHERS)

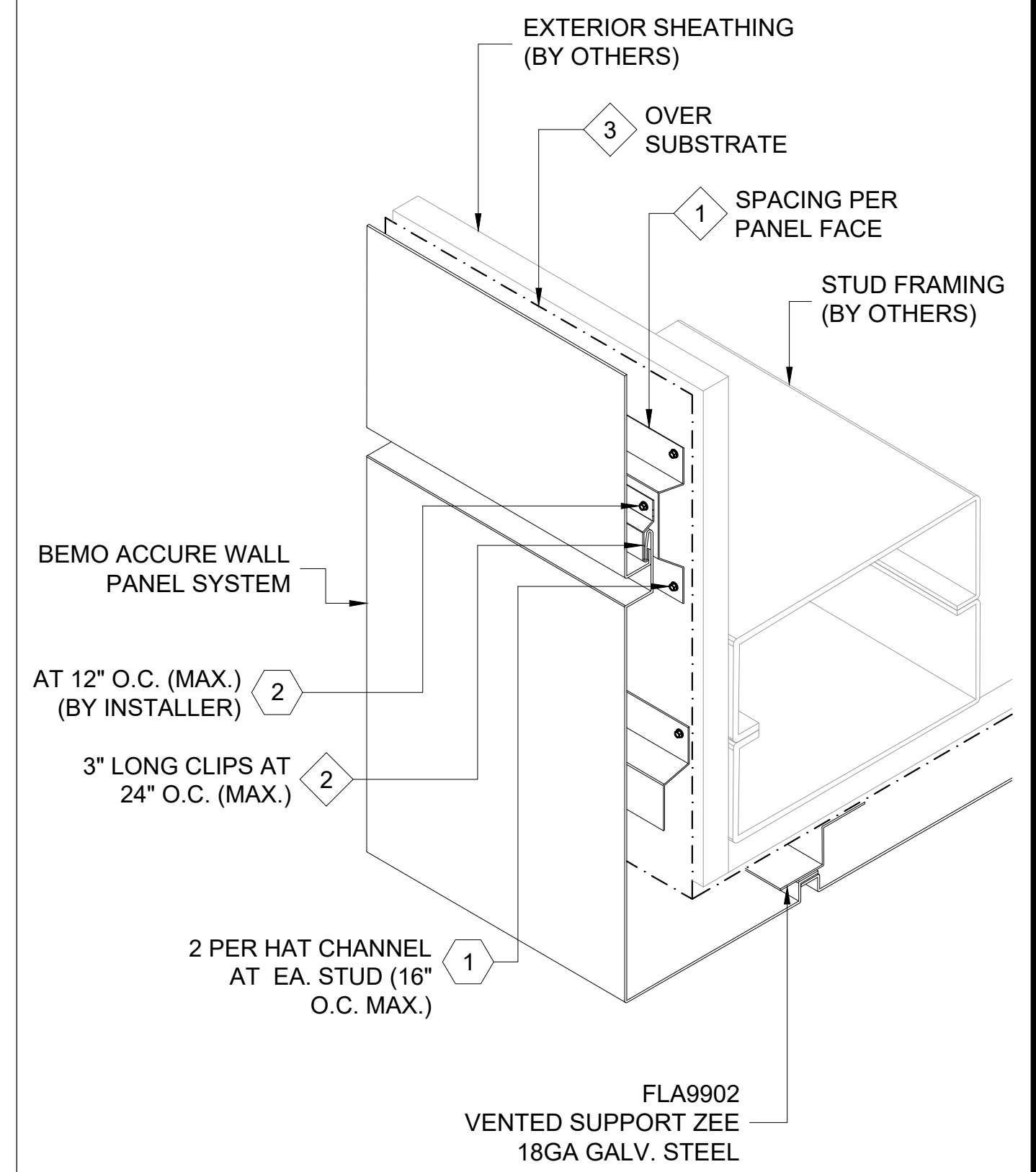

ISOMETRIC VIEW

[NOTE: ISOMETRIC VIEW IS FOR VISUALIZATION ONLY - OBJECTS NOT TO SCALE]



**BEMO STANDARD DETAILS
ACCURE WALL PANELS**

PROJECT ADDRESS _____
CUSTOMER NAME _____
ARCHITECT NAME _____

DRAWN:	JON GOSS	2/18/22
CHECKED:		
PROJECT NUMBER:	####	
NO.	REVISION / ISSUE	DATE

DWG TITLE
SOFFIT/FASCIA DETAIL

SCALE 6" = 1'-0"	DWG NO. D1
---------------------	----------------------