

**NOTES:**  
 1. SYSTEM INSTALLS BOTTOM TO TOP, LEFT TO RIGHT.  
 2. ACTUAL DIMENSIONS FOR FUSION ACM PANELS TO BE DETERMINED IN FIELD.  
 3. FRAMING SHOWN IS AN EXAMPLE ONLY. ACTUAL SUPPORT TO BE VERIFIED IN FIELD.  
 4. ALL FASTENERS MUST PENETRATE 3/4" MIN. THROUGH SUBSTRATE AND FRAMING.

THIS DETAIL IS GENERAL IN NATURE AND WILL BE MODIFIED TO MEET JOB SPECIFIC CONDITIONS

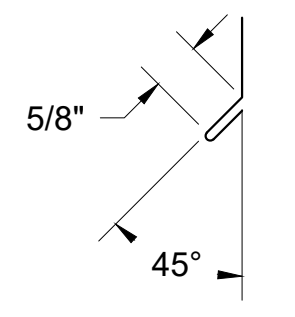

DRIP HEM

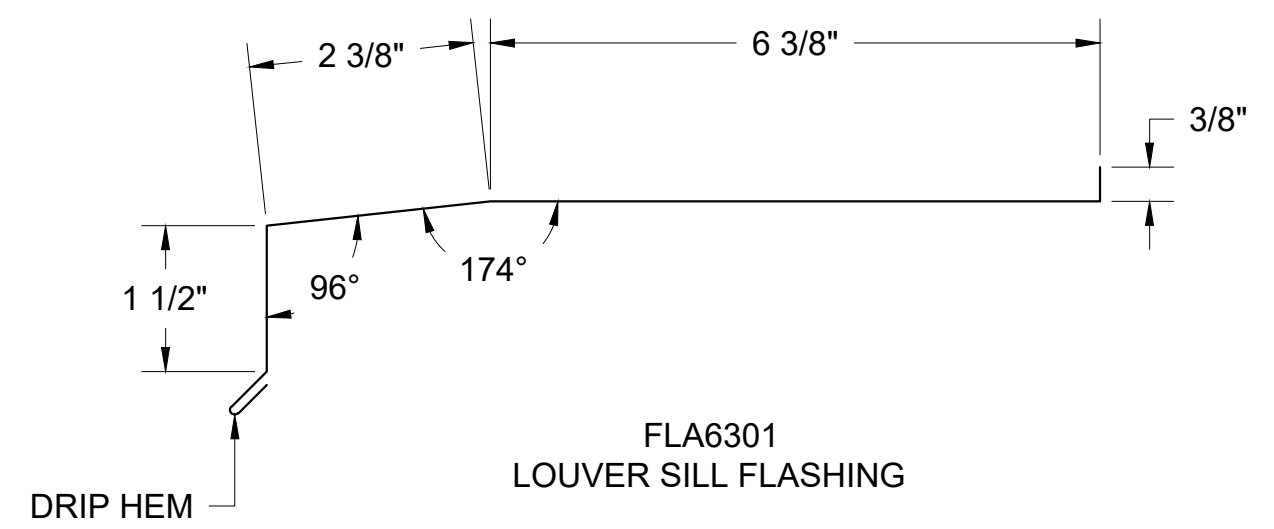

FLA6301 LOUVER SILL FLASHING

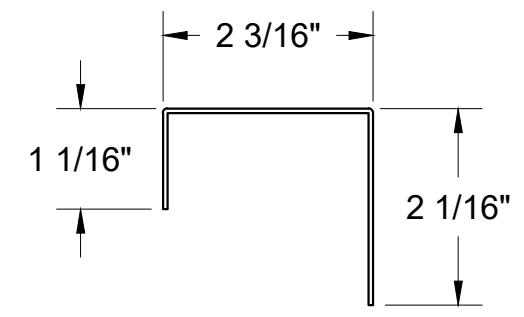

FLA9902 SILL SUPPORT CHANNEL

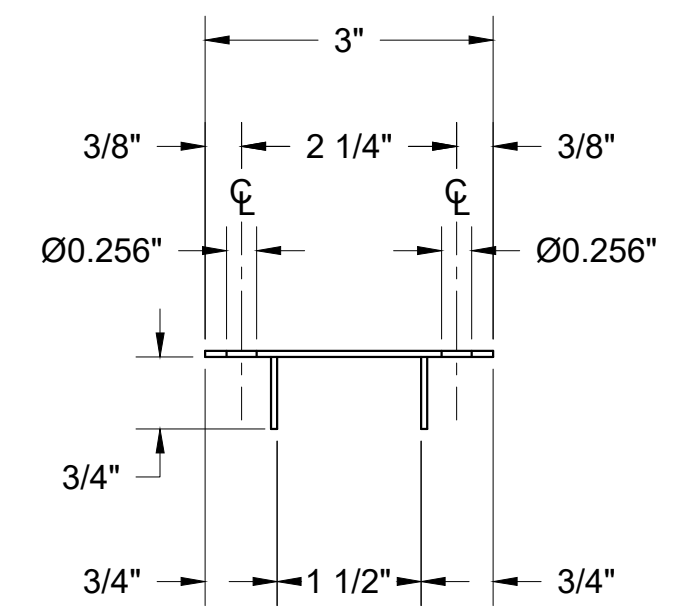

FLA9901 GUTTER SPLICE (PROFILE)

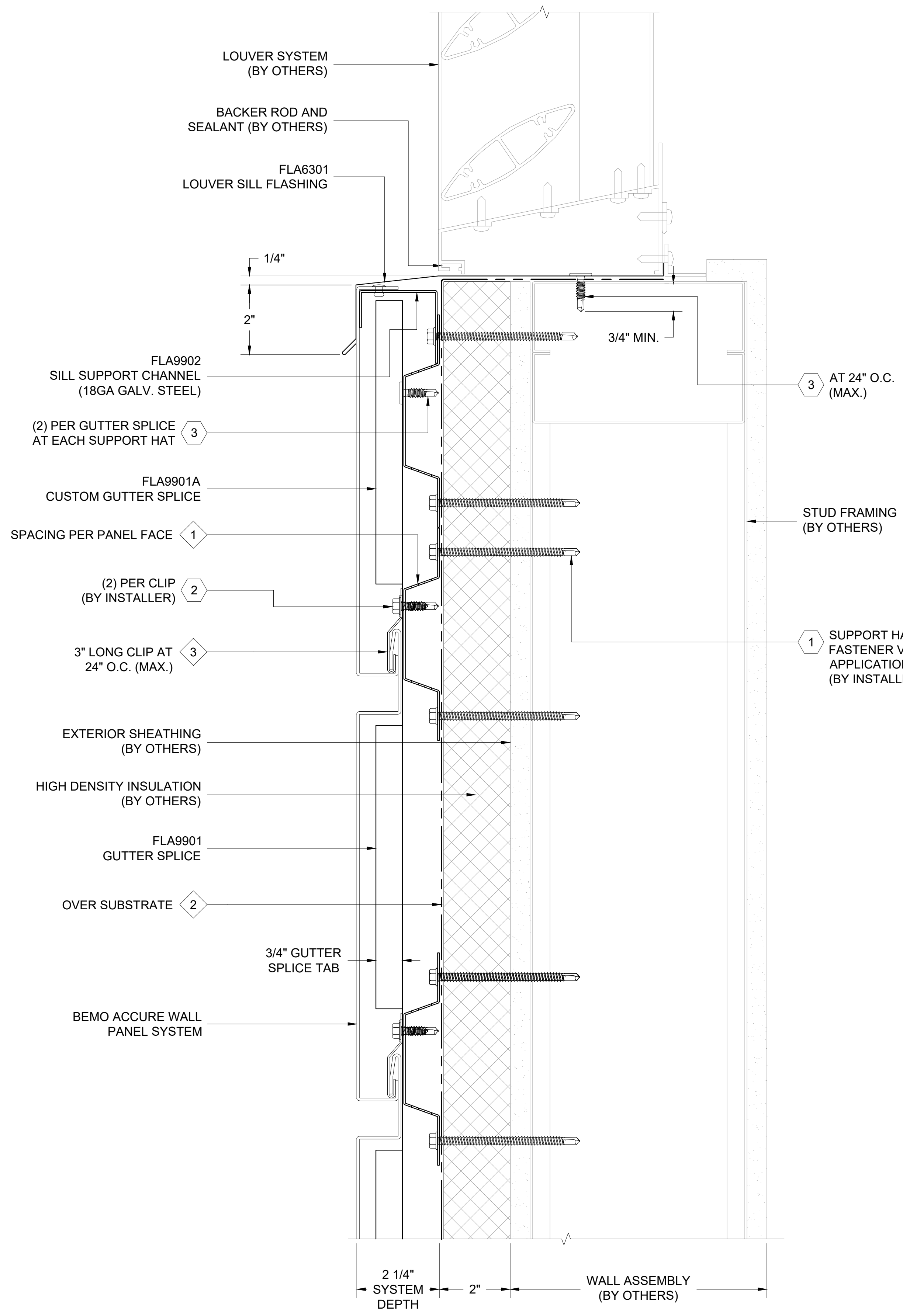

**1 LOUVER SILL DETAIL**  
 D1 REF. ARCH. DET. -

**FASTENER DESIGNATIONS**

MARK	DESCRIPTION	IMAGE
1	APPROVED SUPPORT HAT ATTACHMENT FASTENER	
2	1/4"-14 x 3/4" #3PT SCREW	
3	1/4"-14 x 1" #3PT PANCAKE HEAD SCREW	
4	3/16" POP RIVET	
5		
6		
7		
8		
9		
10		
11		
12		

\* (1000 HRS OF CORROSION RESISTANT COATING IN ACCORDANCE WITH ASTM B117)

**MATERIAL DESIGNATIONS**

MARK	DESCRIPTION
1	STRFH54 VENTED 1" DEEP HAT CHANNEL (18 GA. GALV. STEEL)
2	BEMO "40 MIL HT MEMBRANE" (3'x 65' ROLLS)
3	BEMO ACCURE PANEL CLIP (4" LONG AT 24" O.C. MAX)
4	APPROVED SEALANT (15LF COVERAGE - TUBES) - (BY OTHERS)
5	
6	
7	
8	
9	
10	
11	
12	

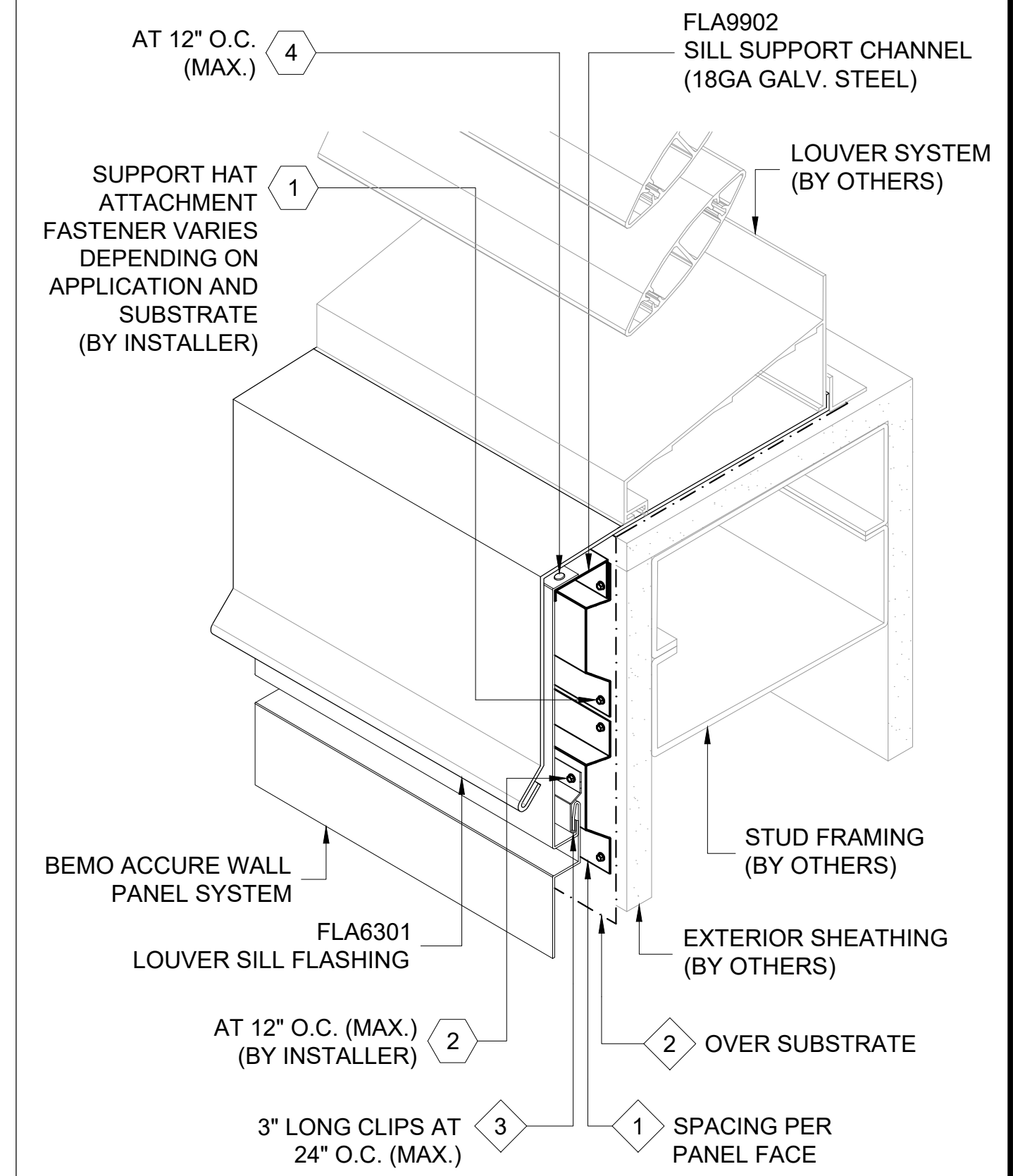

ISOMETRIC VIEW

[NOTE: ISOMETRIC VIEW IS FOR VISUALIZATION ONLY - OBJECTS NOT TO SCALE]



BEMO STANDARD DETAILS  
 ACCURE WALL PANELS

PROJECT ADDRESS

CUSTOMER NAME

ARCHITECT NAME

DRAWN:	JON GOSS	2/18/22
CHECKED:		
PROJECT NUMBER:	####	
NO.	REVISION / ISSUE	DATE

DWG TITLE  
**LOUVER SILL DETAIL**

SCALE  
 6" = 1'-0"

DWG NO.  
**D1**