

- NOTES:**
1. SYSTEM INSTALLS BOTTOM TO TOP, LEFT TO RIGHT.
 2. ACTUAL DIMENSIONS FOR RAINSCREEN ACM PANELS TO BE DETERMINED IN FIELD.
 3. FRAMING SHOWN IS AN EXAMPLE ONLY. ACTUAL SUPPORT TO BE VERIFIED IN FIELD.
 4. ALL FASTENERS MUST PENETRATE 3/4" MIN. THROUGH SUBSTRATE AND FRAMING.

THIS DETAIL IS GENERAL IN NATURE AND WILL BE MODIFIED TO MEET JOB SPECIFIC CONDITIONS

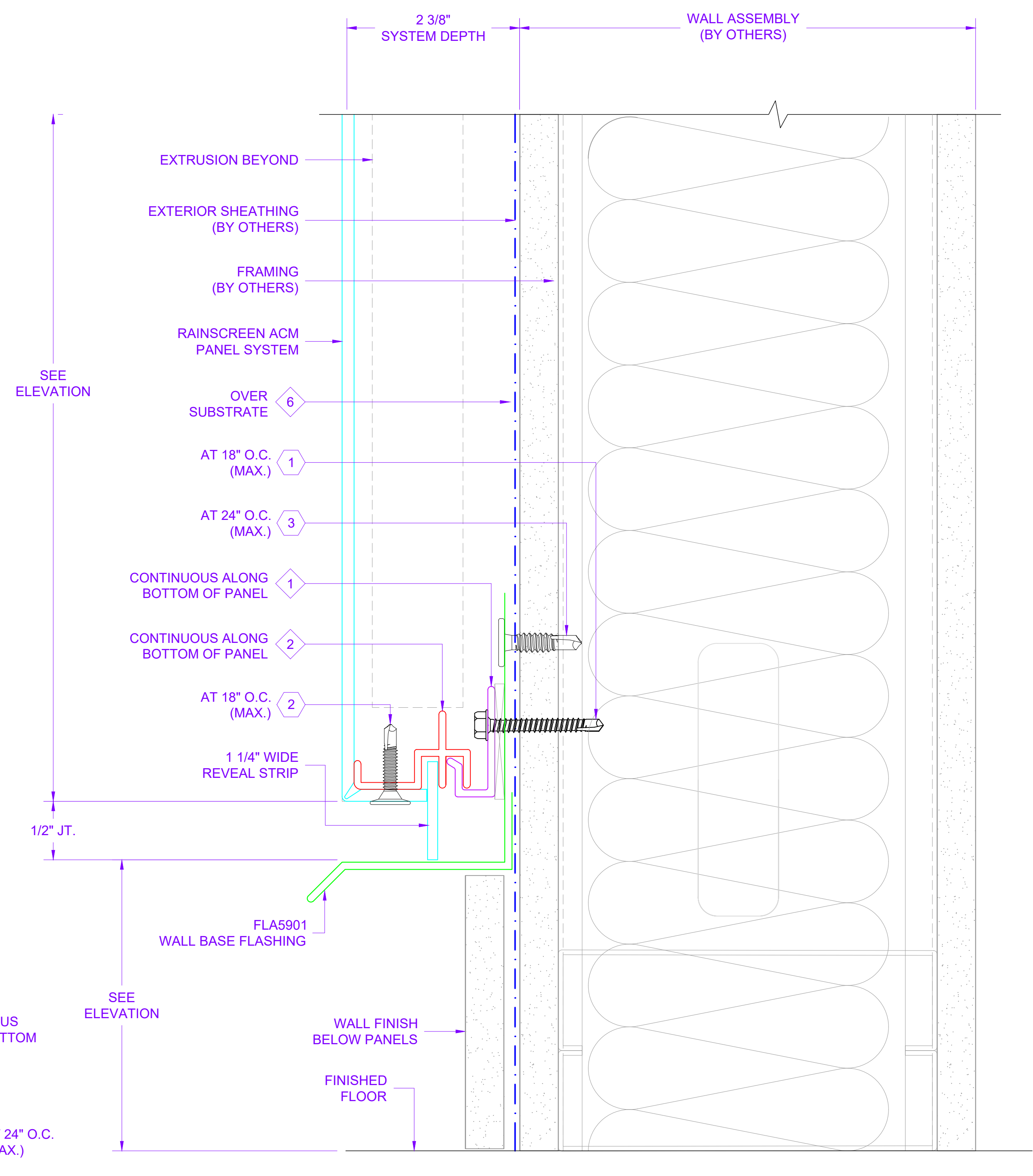
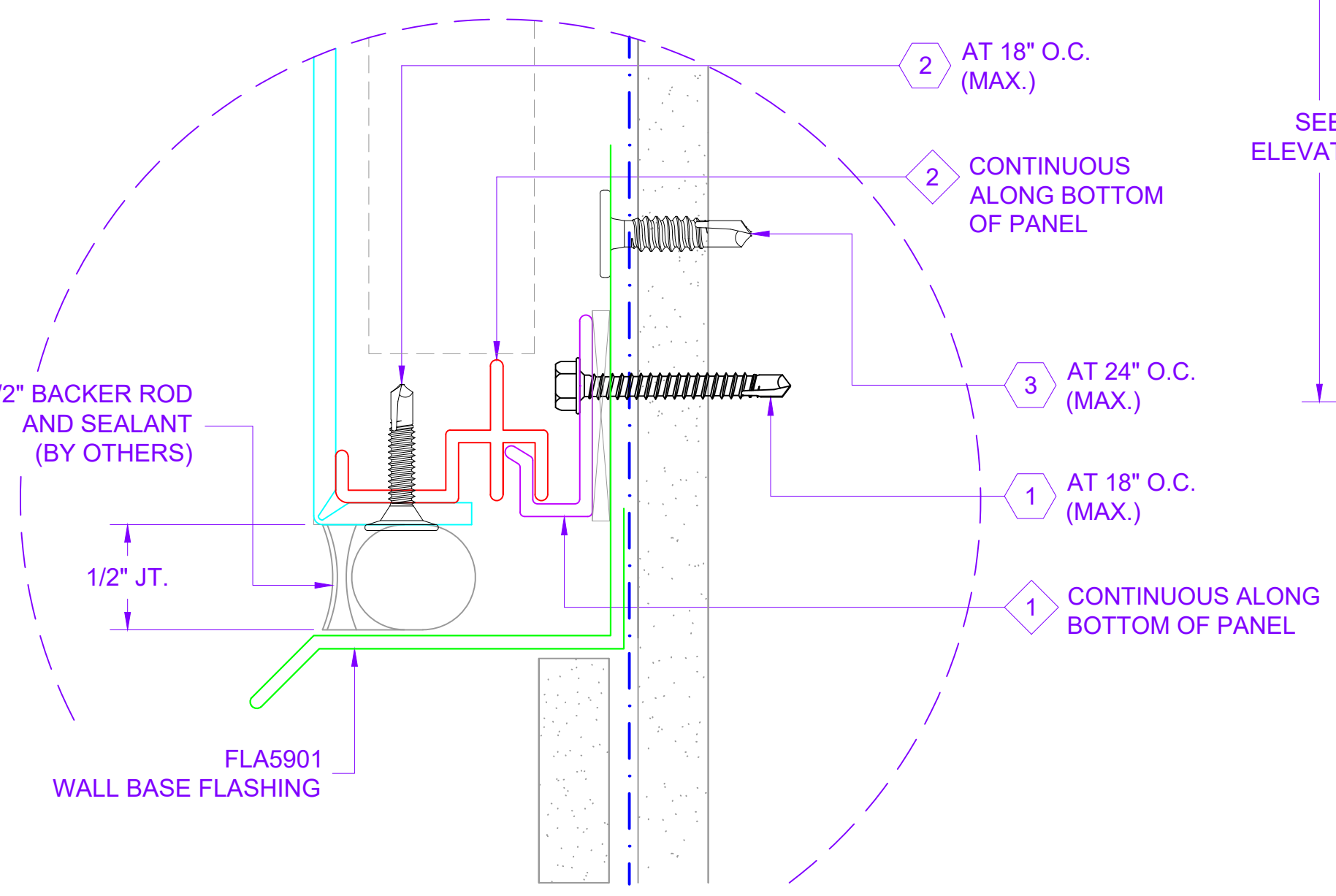
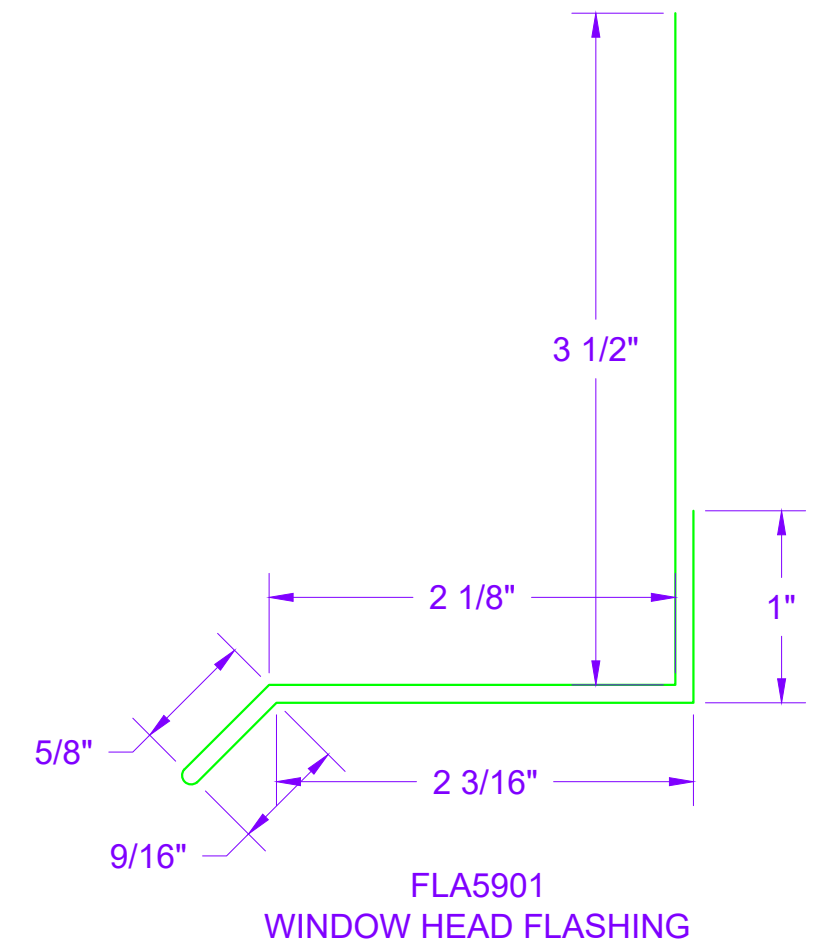

1 WALL BASE DETAIL
D1 REF. ARCH. DET. -

FASTENER DESIGNATIONS

MARK	DESCRIPTION	IMAGE
1	1/4"-14x 2 1/2" TEK-3 STAINLESS STEEL SCREW	
2	#8-18x1" PHIL FLAT SELF DRILL #3 PT SCREW	
3	#10x 3/4" PANCAKE HEAD SCREW	
4		
5		
6		
7		
8		
9		
10		
11		
12		

* (1000 HRS OF CORROSION RESISTANT COATING IN ACCORDANCE WITH ASTM B117)

MATERIAL DESIGNATIONS

MARK	DESCRIPTION
1	BOTTOM STARTER EXTRUSION - CONTINUOUS (DIE # - ___)
2	TOP STARTER EXTRUSION - CONTINUOUS (DIE # - ___)
3	BOTTOM MID CLIP EXTRUSION - CONTINUOUS (DIE # - ___)
4	TOP MID CLIP EXTRUSION - CONTINUOUS (DIE # - ___)
5	TERMINATION EXTRUSION - CONTINUOUS (DIE # - ___)
6	BEMO "40 MIL HT MEMBRANE
7	1/4" PLASTIC HORSESHOE SHIM
8	
9	
10	
11	
12	

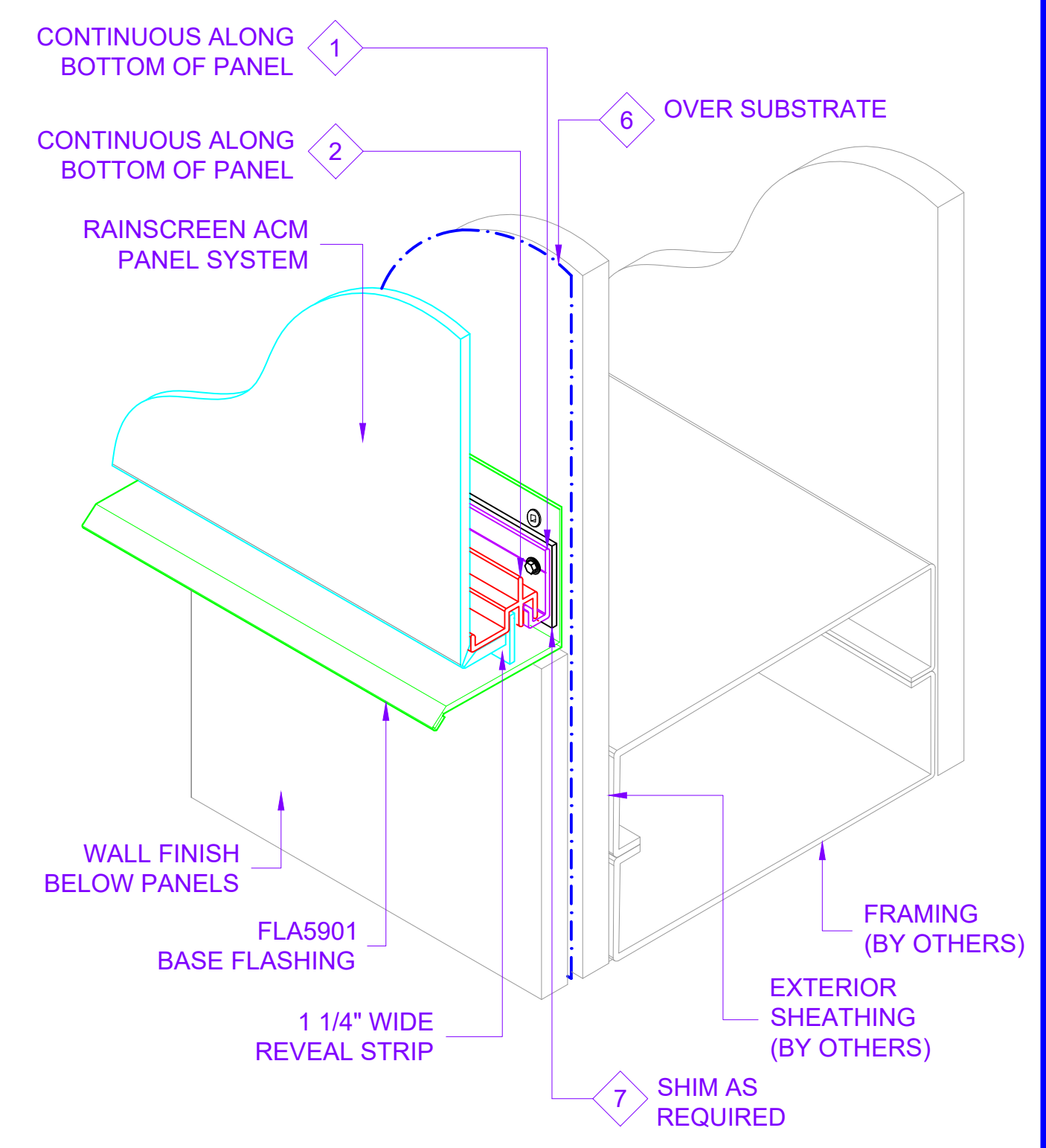

[NOTE: ISOMETRIC VIEW IS FOR VISUALIZATION ONLY - OBJECTS NOT TO SCALE]



FOR SUBMITTAL DATE

BEMO STANDARD DETAILS
ASPECT RAINSCREEN ACM PANEL SYSTEM

PROJECT ADDRESS

CUSTOMER NAME

ARCHITECT NAME

DRAWN:	DRAWN BY:	DATE:
CHECKED:	CHECKED BY:	DATE:
PROJECT NUMBER: #####		
NO.	REVISION / ISSUE	DATE

DWG TITLE
WALL BASE

SCALE 1' = 1'-0"	DWG NO. D1
REV	