

- NOTES:**
- ALL SNOW STOP COMPONENTS ARE MILL FINISHED ALUMINUM (6061-T6 ALUMINUM) AND ALL BOLTS ARE STAINLESS STEEL (18-8 STAINLESS) UNLESS SPECIFIED OTHERWISE.
 - MATERIAL: 6061 T6 ALUMINUM.
 - ALL RADIUS TO BE .025 (U.N.O.)
 - TOLERANCE: .XX = +.03 .XXX = .005
ANGLES: SNOW FENCE +1° SNOW CLAMP +2°
 - ULTIMATE TESTED CLAMPING FORCE: 1,185 lbs. (592 LBS. ALLOWABLE).
 - CONSULT MANUFACTURER FOR REQUIRED SNOW GUARD SPACING.
 - ALL FASTENERS MUST PENETRATE 3/4" MIN. THROUGH SUBSTRATE.

THIS DETAIL IS GENERAL IN NATURE AND WILL BE MODIFIED TO MEET JOB SPECIFIC CONDITIONS

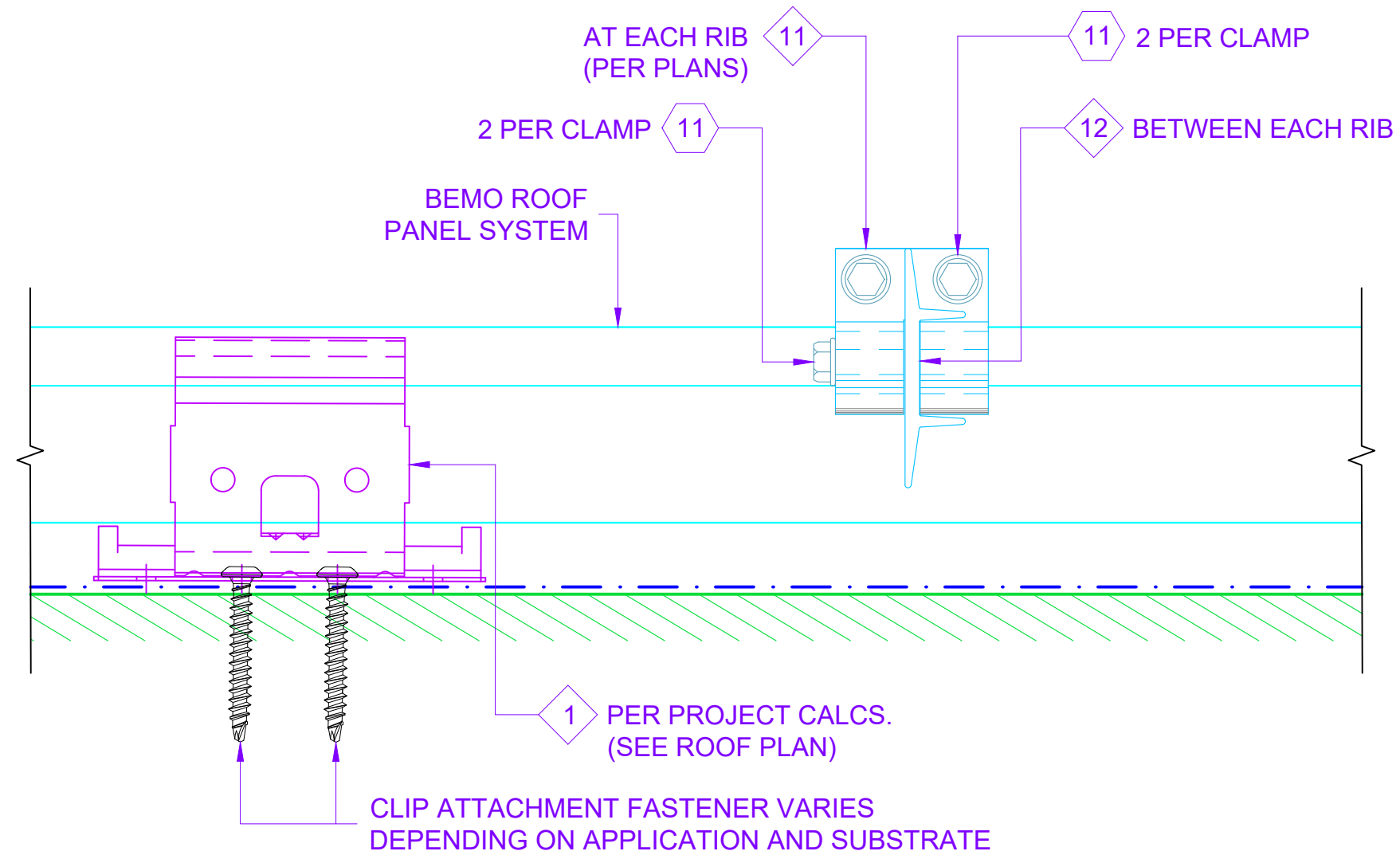

1 SNOW RETENTION DETAIL
D1 REF. ARCH. DET. -

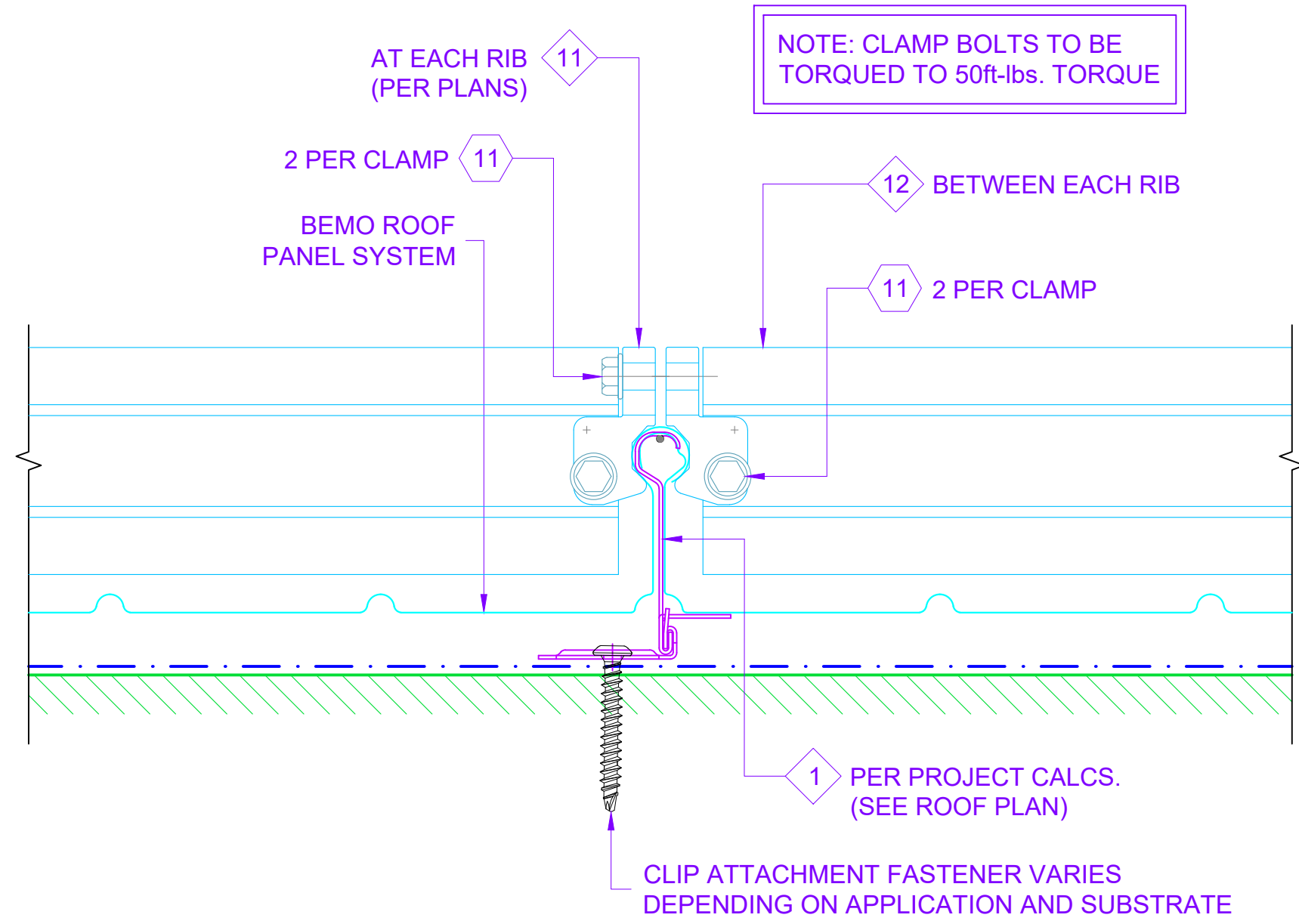

2 SNOW RETENTION DETAIL
D1 REF. ARCH. DET. -

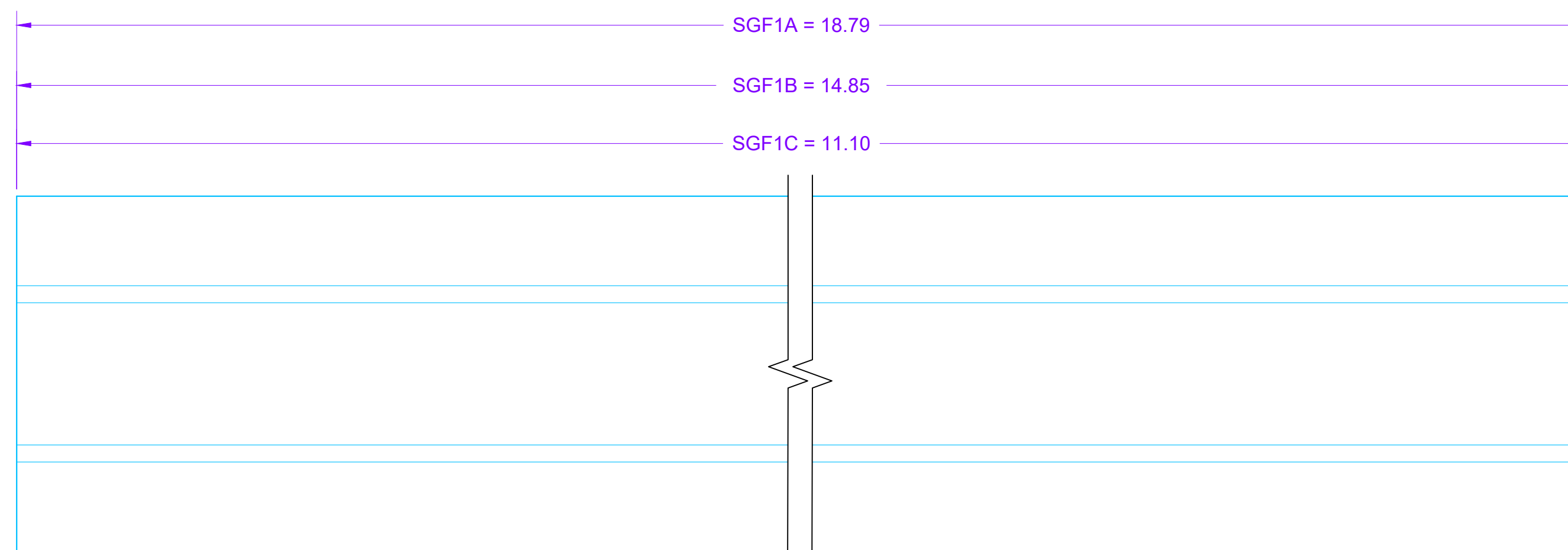
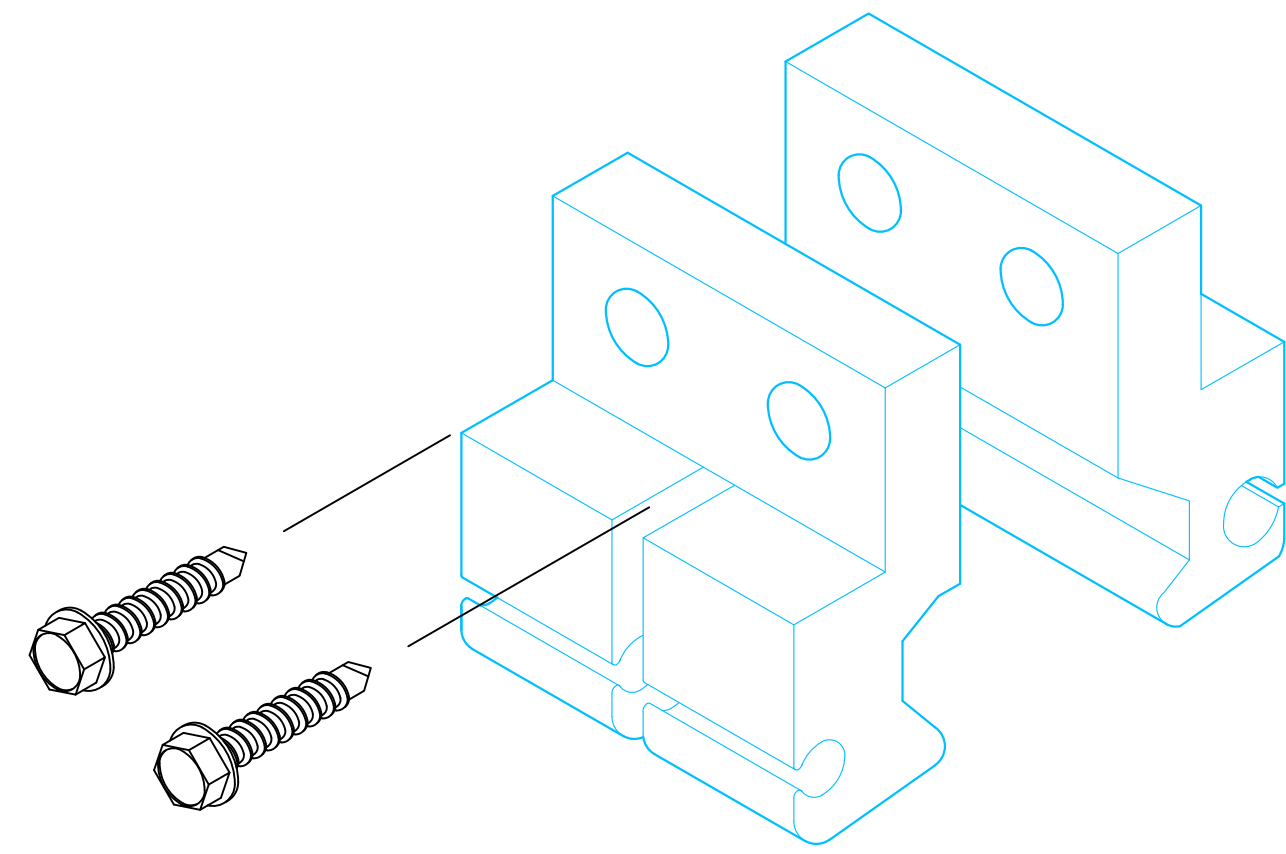

SNOW FENCE

SGF1A --- BEMO 500 PANEL
SGF1B --- BEMO 400 PANEL
SGF1C --- BEMO 305 PANEL

FASTENER DESIGNATIONS

MARK	DESCRIPTION	IMAGE
1	#14-10 x 7" DEKFAST SCREW (OR COMPARABLE)	
2	#14-10 x 2" DEKFAST SCREW (OR COMPARABLE)	
3	1/4"-14x 1 1/2" HWH TEK-3 (W/ BONDED WASHER)	
4	1/4"-20x 3/4" STAINLESS STEEL BOLT ASSEMBLY	
5	1/4"-14x 7/8" HWH TEK-1 (W/ BONDED WASHER)	
6	#10x 3/4" PANCAKE HEAD SCREW	
7	1/4"Ø BULB-TITE RIVET (W/ BONDED WASHER)	
8	3/16"Ø CLOSED END S.S. RIVET	
9	#14-10x 1" SELF-TAPPING (W/ BONDED WASHER)	
10	1/4"-14x 1" TEK-3 STAINLESS STEEL SCREW*	
11	#12-14x 1 1/2" TEK-3 STAINLESS STEEL SCREW*	
12	1/4"-14x 3" PANCAKE HEAD 316SS TYPE "B" FASTENER	

* (1000 HRS OF CORROSION RESISTANT COATING IN ACCORDANCE WITH ASTM B117)

MATERIAL DESIGNATIONS

MARK	DESCRIPTION
1	BEMO HOOK CLIP W/ GALV. BASE
2	BEMO FIXED HOOK CLIP
3	BEMO GABLE HALTER CLIP (30" O.C. MAX.)
4	BEMO METAL/FOAM PROFILE CLOSURE
5	KEYHOLE CLOSURE
6	EXPANDING FOAM TAPE (18 L.F. ROLLS)
7	"GRIP-STRUT" WALKWAY PLANK, 11 7/8" W x 12'-0" LG (2 PLANK WALKWAY)
8	BEMO 300-H OR 300-V STAINLESS STEEL UTILITY CLAMP
9	1/8"x 1" WIDE SEALING TAPE (65 L.F. ROLLS) - (BY OTHERS)
10	BEMO "40 MIL HT MEMBRANE" (3'x 65' ROLLS)
11	BEMO SNOW STOP CLAMP
12	BEMO SNOW GUARD FENCE

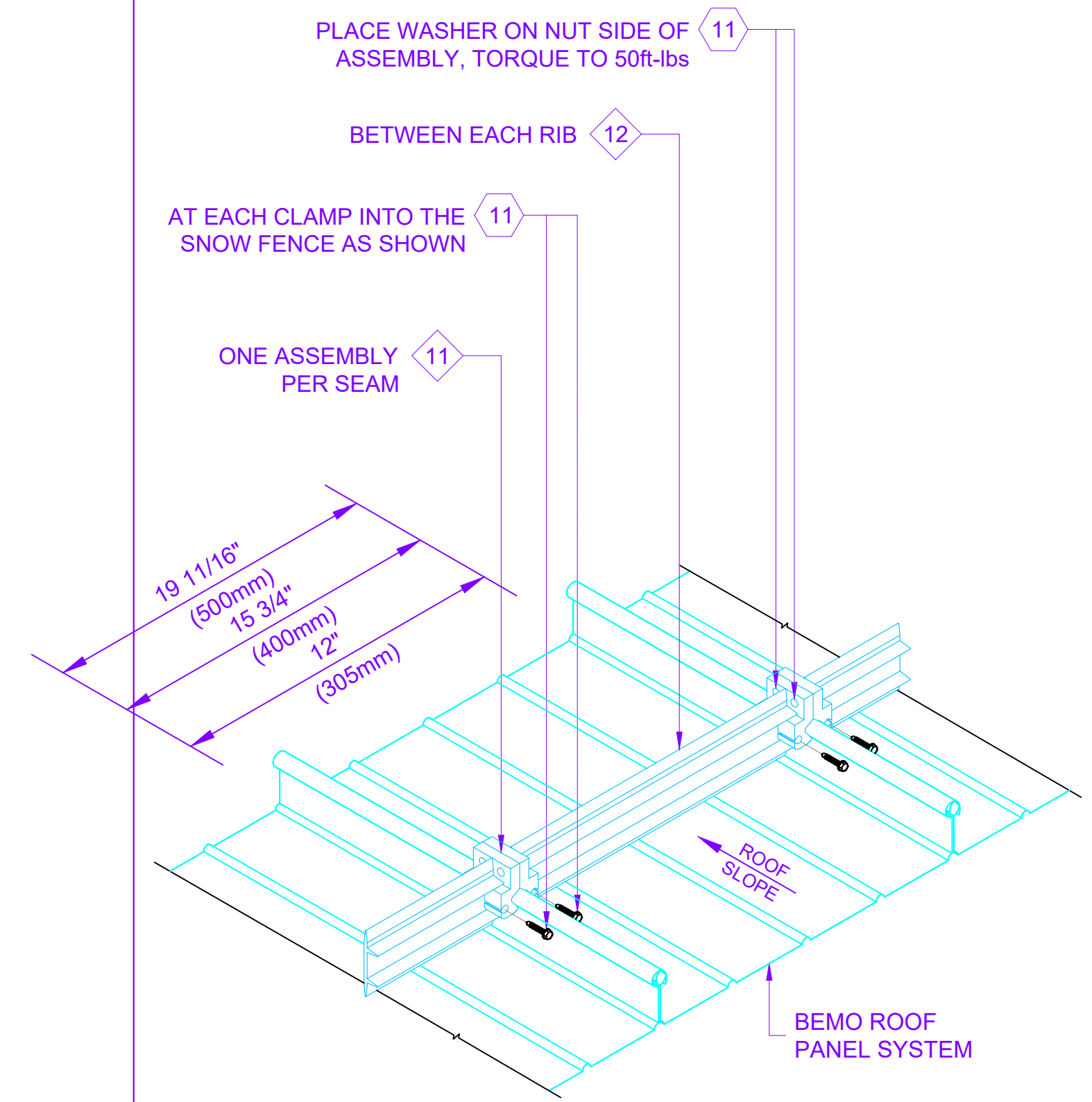

ISOMETRIC VIEW

[NOTE: ISOMETRIC VIEW IS FOR VISUALIZATION ONLY - OBJECTS NOT TO SCALE]



BEMO STANDARD DETAILS
SNOW RETENTION SYSTEM DETAIL

PROJECT ADDRESS

CUSTOMER NAME

ARCHITECT NAME

DRAWN:	D. GOSS	1/25/21
CHECKED:		
PROJECT NUMBER:		
NO.	REVISION / ISSUE	DATE

DWG TITLE
BEMO STANDARD DETAIL

SCALE 6" = 1'-0"	DWG NO. D1
---------------------	----------------------