

- NOTES:**
1. WHEN INSTALLING THE GABLE HALTER CLIPS, LAYOUT SPACING SO THAT A CLIP FALLS ON THE DOWN SLOPE SIDE OF ALL RAKEWALL FLASHING LAP JOINTS. DO NOT PLACE ANY FASTENERS IN THE FLASHING LAP ITSELF. (SEE DETAIL BELOW)
 2. FLASHING DIMENSIONS PER FIELD CONDITIONS.
 3. FLASHING WIDTH PER PLAN; SUPPORT REQ'D WHEN WIDTH IS GREATER THAN 6"
 4. ALL FASTENERS MUST PENETRATE 3/4" MIN. THROUGH SUBSTRATE.

THIS DETAIL IS GENERAL IN NATURE AND WILL BE MODIFIED TO MEET JOB SPECIFIC CONDITIONS

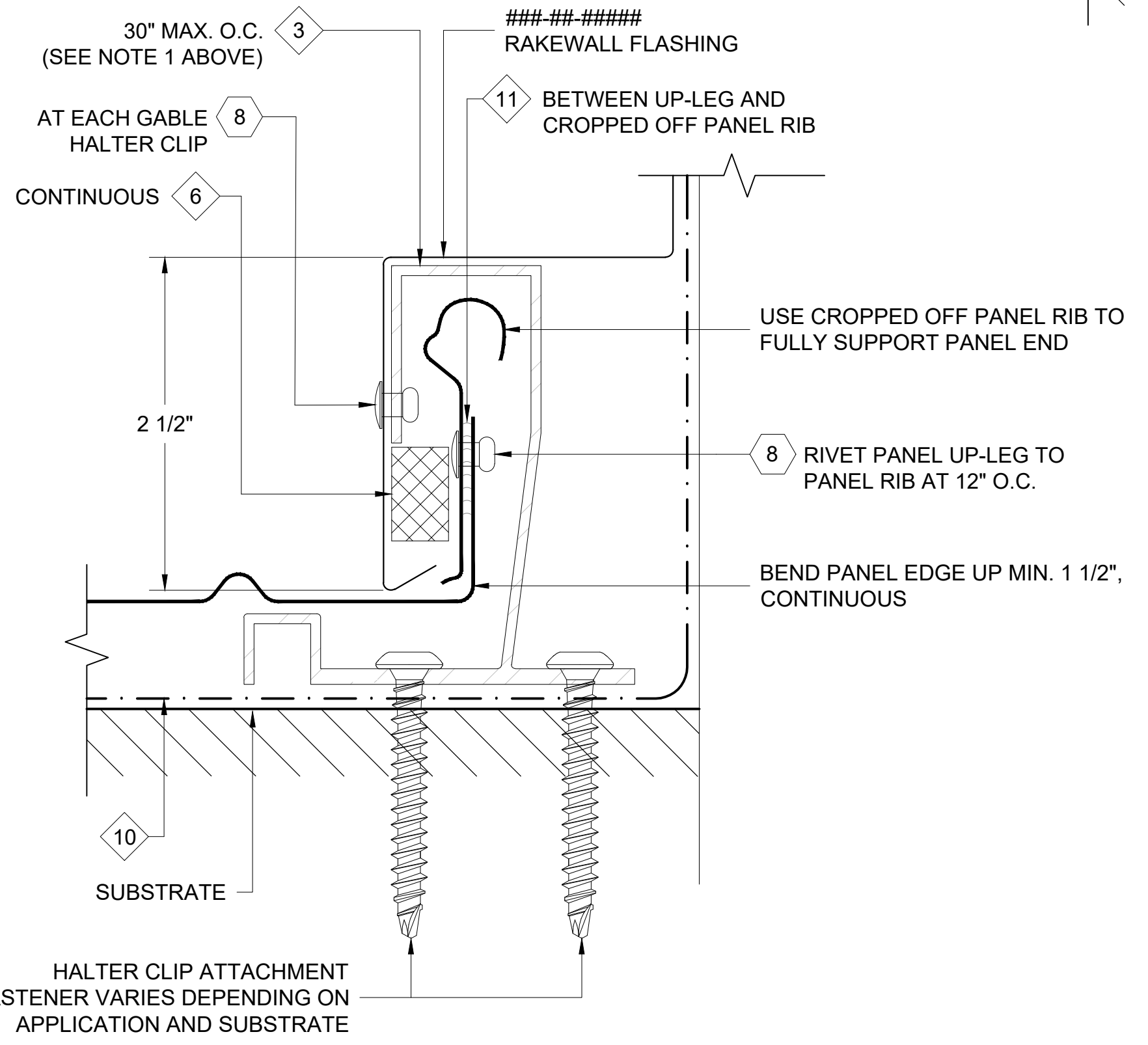

1 RAKEWALL DETAIL
D1 REF. ARCH. DET. -

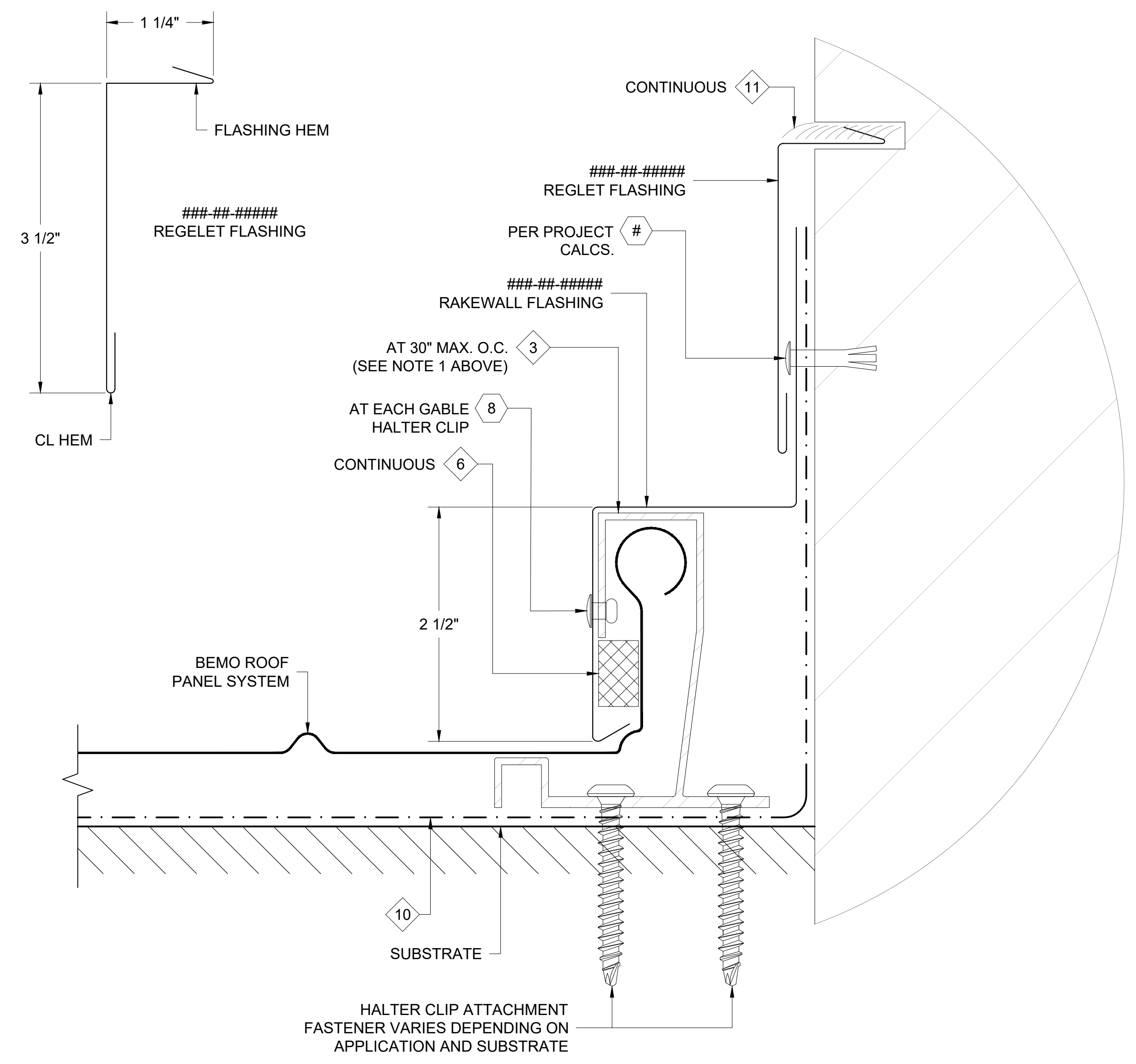
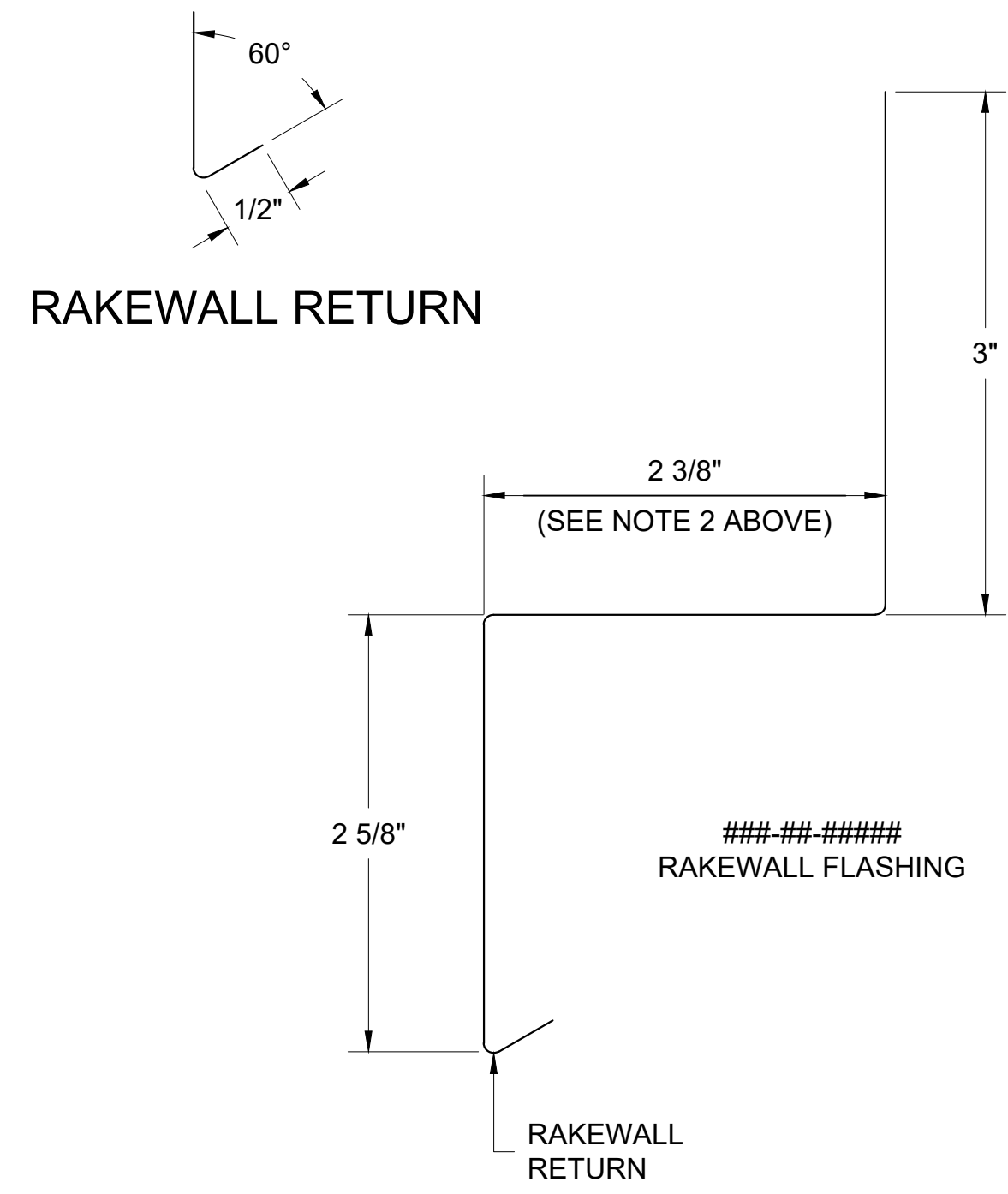
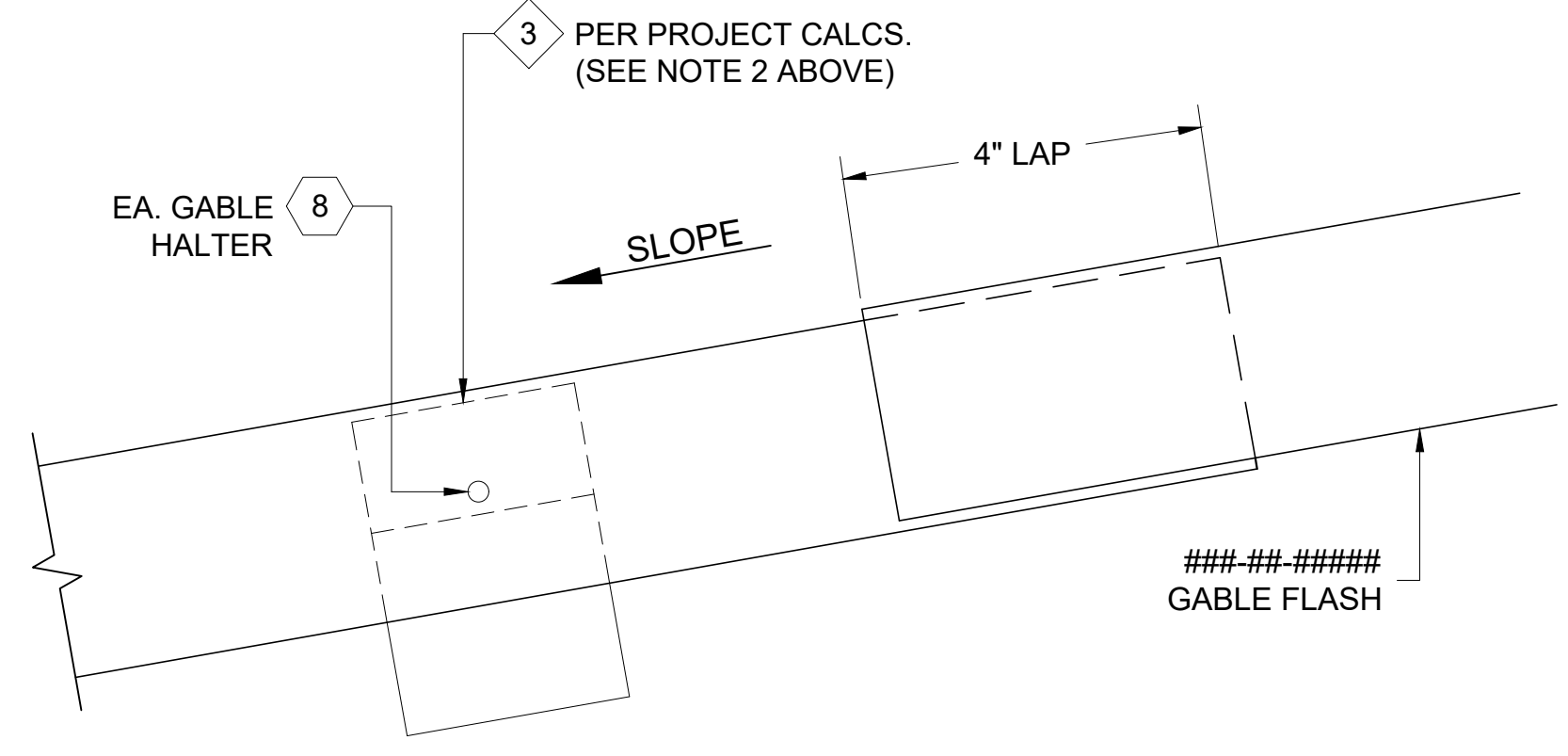

TYPICAL RAKEWALL FLASHING LAP DETAIL

FASTENER DESIGNATIONS		
MARK	DESCRIPTION	IMAGE
1	#14-10 x 7" DEKFAST SCREW (OR COMPARABLE)	
2	#14-10 x 2" DEKFAST SCREW (OR COMPARABLE)	
3	1/4"-14x 1 1/2" HWH TEK-3 (W/ BONDED WASHER)	
4	1/4"-20x 3/4" STAINLESS STEEL BOLT ASSEMBLY	
5	1/4"-14x 7/8" HWH TEK-1 (W/ BONDED WASHER)	
6	#10x 3/4" PANCAKE HEAD SCREW	
7	1/4"Ø BULB-TITE RIVET (W/ BONDED WASHER)	
8	3/16"Ø CLOSED END S.S. RIVET	
9	#14-10x 1" SELF-TAPPING (W/ BONDED WASHER)	
10	1/4"-14x 1" TEK-3 STAINLESS STEEL SCREW*	
11	#12-14x 1 1/2" TEK-3 STAINLESS STEEL SCREW*	
12	1/4"-14x 3" PANCAKE HEAD 316SS TYPE "B" FASTENER	

* (1000 HRS OF CORROSION RESISTANT COATING IN ACCORDANCE WITH ASTM B117)

MATERIAL DESIGNATIONS	
MARK	DESCRIPTION
1	BEMO HOOK CLIP W/ GALV. BASE
2	BEMO FIXED HOOK CLIP
3	BEMO GABLE HALTER CLIP (30" O.C. MAX.)
4	BEMO METAL/FOAM PROFILE CLOSURE
5	KEYHOLE CLOSURE
6	EXPANDING FOAM TAPE (18 L.F. ROLLS)
7	"GRIP-STRUT" WALKWAY PLANK, 11 7/8" W x 12'-0" LG (2 PLANK WALKWAY)
8	BEMO 300-H OR 300-V STAINLESS STEEL UTILITY CLAMP
9	1/8"x 1" WIDE SEALING TAPE (65 L.F. ROLLS) - (BY OTHERS)
10	BEMO "40 MIL HT MEMBRANE" (3'x 65' ROLLS)
11	"APPROVED" SEALANT (15 L.F. COVERAGE - TUBES) - (BY OTHERS)
12	4"x 6" BEARING PLATE (AT EACH CLIP)

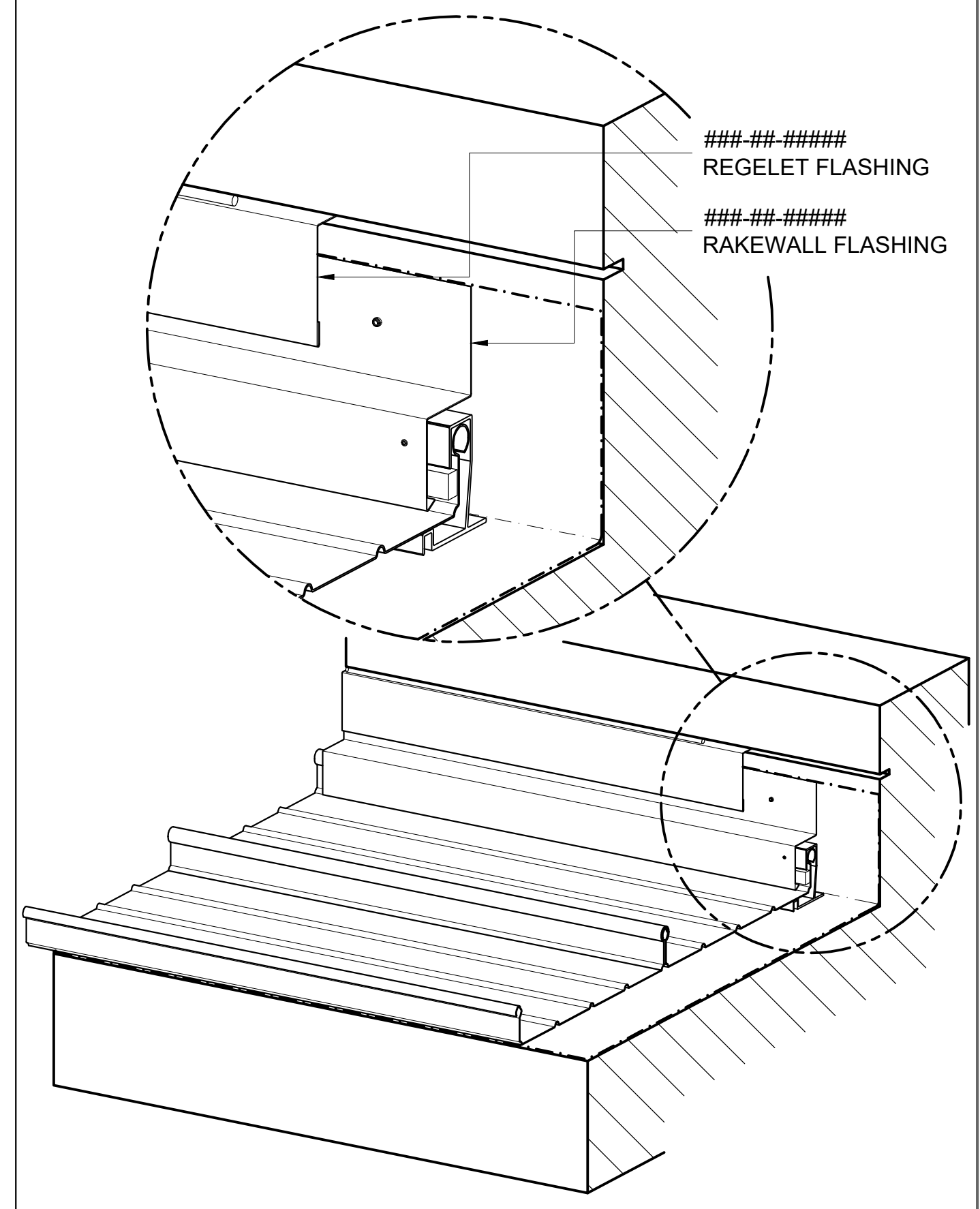

ISOMETRIC VIEW

[NOTE: ISOMETRIC VIEW IS FOR VISUALIZATION ONLY - OBJECTS NOT TO SCALE]



BEMO STANDARD DETAILS			
RAKEWALL DETAIL			
PROJECT ADDRESS		CUSTOMER NAME	ARCHITECT NAME

DRAWN:	D. GOSS	1/25/21
CHECKED:		
PROJECT NUMBER:		
NO.	REVISION / ISSUE	DATE

DWG TITLE
BEMO STANDARD DETAIL

SCALE 1' = 1'-0"	DWG NO. D1
---------------------	----------------------