

- NOTES:**
- DO NOT FASTEN CURB FLASHINGS TO ROOF CURB; CURB FLASHINGS TO MOVE WITH PANEL SYSTEM DURING THERMAL EXPANSION AND CONTRACTION.
  - ACTUAL DIMENSIONS FOR CURB FLASHINGS TO BE DETERMINED IN FIELD.
  - A COUNTERFLASHING MUST BE INSTALLED TO WEATHERTIGHT THE TOP OF THE CURB.
  - STRUCTURAL SHOWN IS AN EXAMPLE ONLY. ACTUAL SUPPORT TO BE VERIFIED IN FIELD.
  - ALL FASTENERS MUST PENETRATE 3/4" MIN. THROUGH SUBSTRATE.

THIS DETAIL IS GENERAL IN NATURE AND WILL BE MODIFIED TO MEET JOB SPECIFIC CONDITIONS

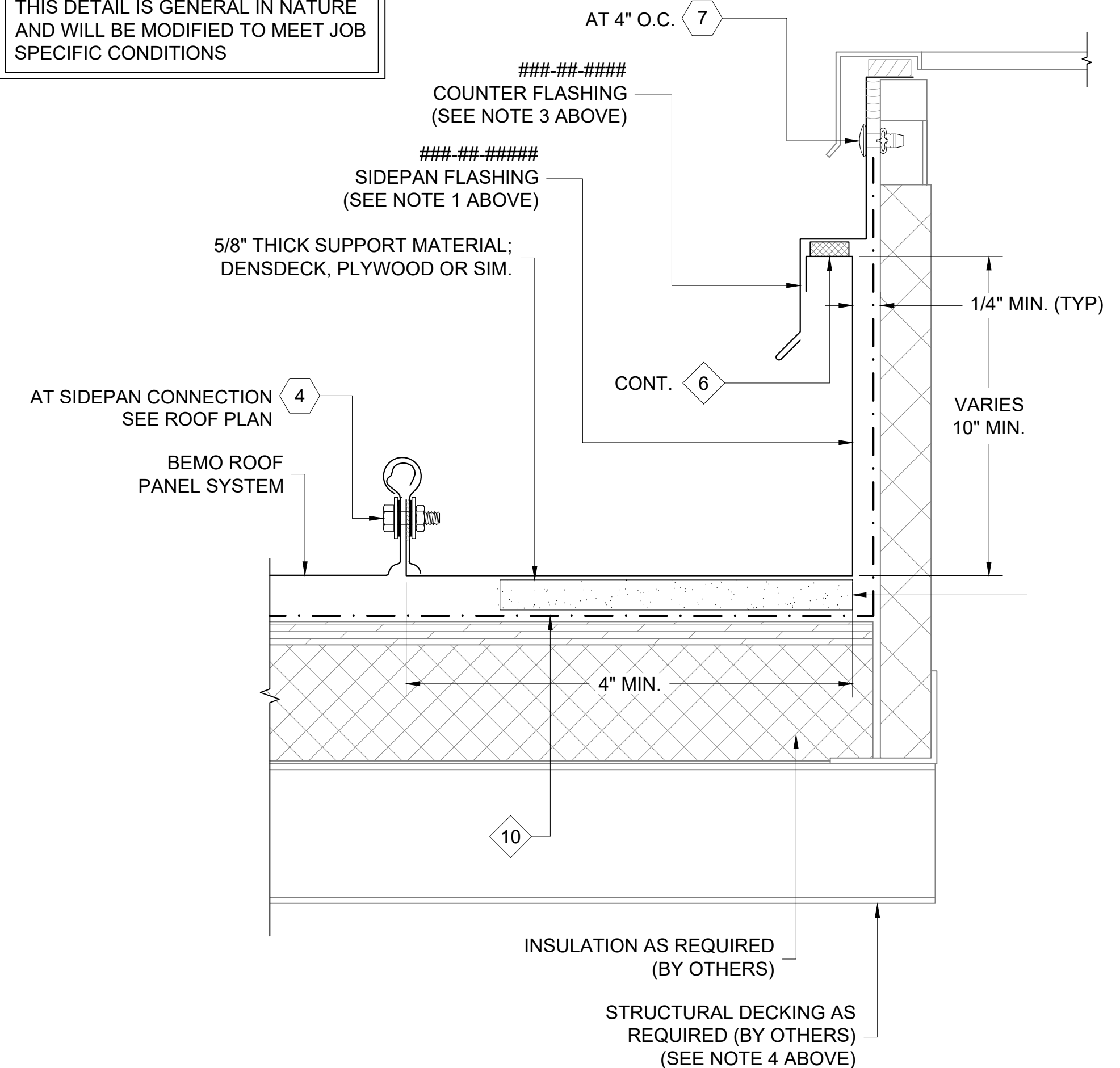

**DETAIL 'A'**

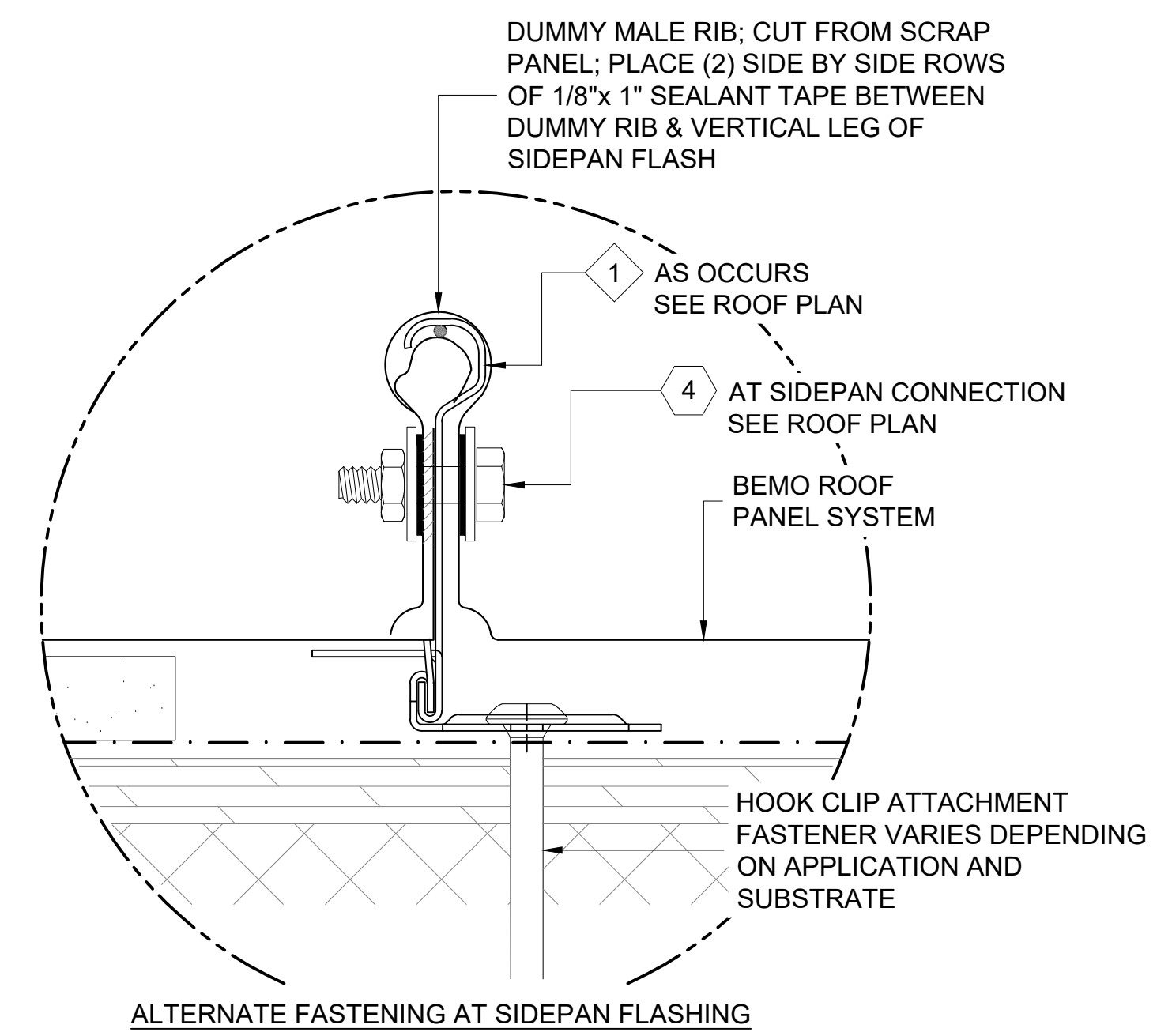

**1 SIDEPAN DETAILS**  
D1 REF. ARCH. DET. -

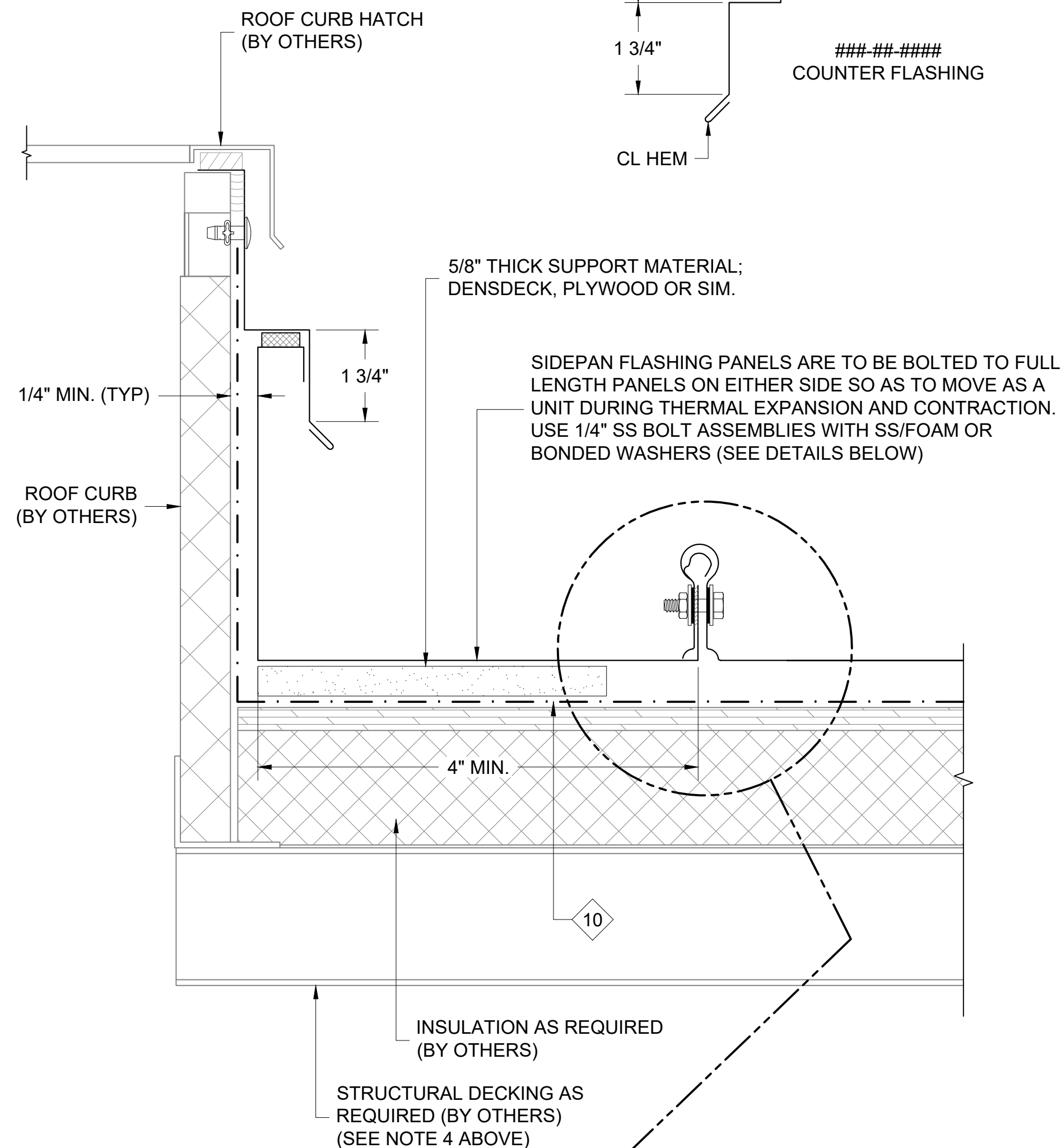

**DETAIL 'B'**

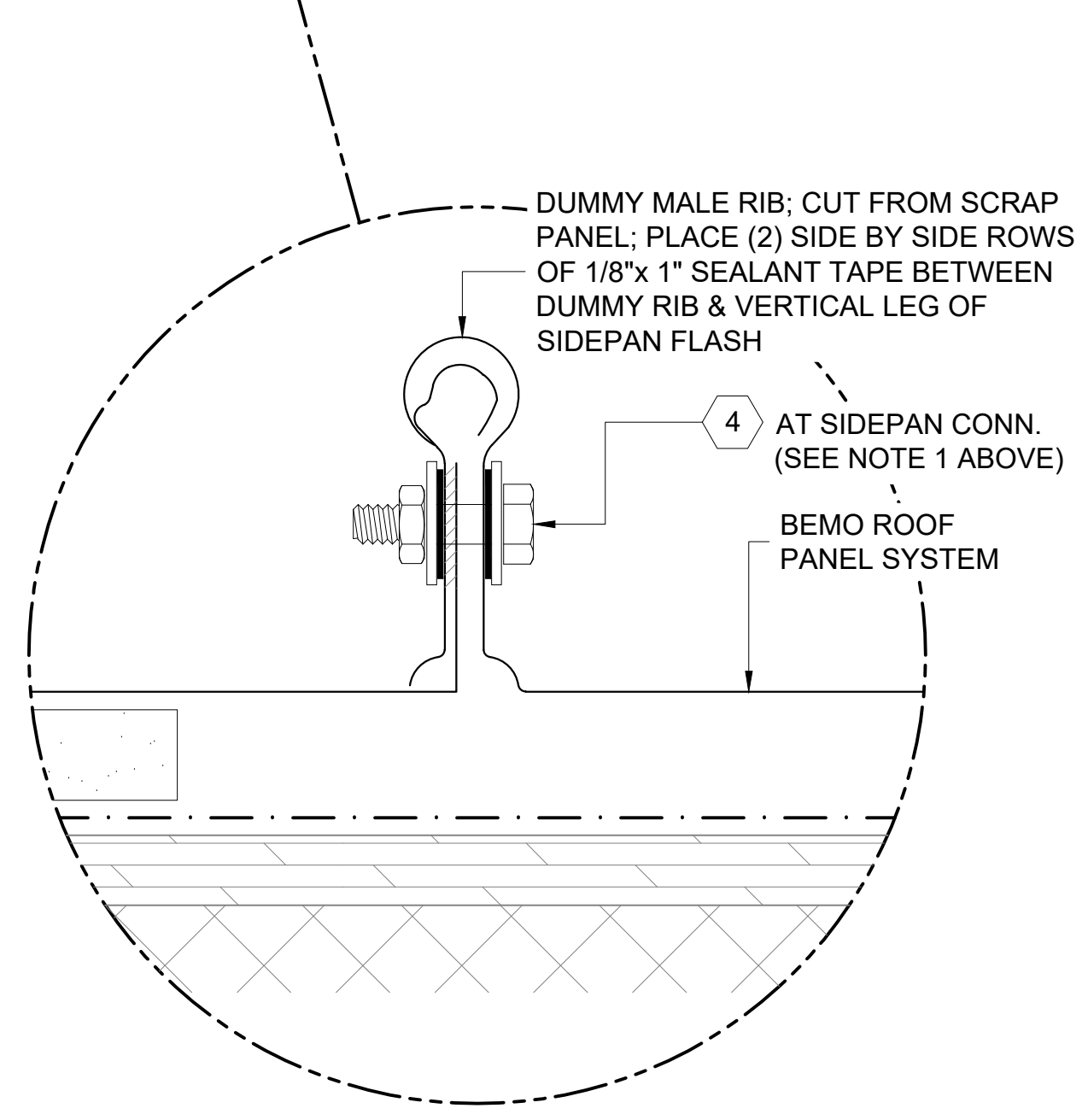

FASTENER DESIGNATIONS		
MARK	DESCRIPTION	IMAGE
1	#14-10 x 7" DEKFAST SCREW (OR COMPARABLE)	
2	#14-10 x 2" DEKFAST SCREW (OR COMPARABLE)	
3	1/4"-14x 1 1/2" HWH TEK-3 (W/ BONDED WASHER)	
4	1/4"-20x 3/4" STAINLESS STEEL BOLT ASSEMBLY	
5	1/4"-14x 7/8" HWH TEK-1 (W/ BONDED WASHER)	
6	#10x 3/4" PANCAKE HEAD SCREW	
7	1/4"Ø BULB-TITE RIVET (W/ BONDED WASHER)	
8	3/16"Ø CLOSED END S.S. RIVET	
9	#14-10x 1" SELF-TAPPING (W/ BONDED WASHER)	
10	1/4"-14x 1" TEK-3 STAINLESS STEEL SCREW*	
11	#12-14x 1 1/2" TEK-3 STAINLESS STEEL SCREW*	
12	1/4"-14x 3" PANCAKE HEAD 316SS TYPE "B" FASTENER	

MATERIAL DESIGNATIONS	
MARK	DESCRIPTION
1	BEMO HOOK CLIP W/ GALV. BASE
2	BEMO FIXED HOOK CLIP
3	BEMO GABLE HALTER CLIP (30" O.C. MAX.)
4	BEMO METAL/FOAM PROFILE CLOSURE
5	KEYHOLE CLOSURE
6	EXPANDING FOAM TAPE (18 L.F. ROLLS)
7	"GRIP-STRUT" WALKWAY PLANK, 11 7/8" W x 12'-0" LG (2 PLANK WALKWAY)
8	BEMO 300-H OR 300-V STAINLESS STEEL UTILITY CLAMP
9	1/8"x 1" WIDE SEALING TAPE (65 L.F. ROLLS) - (BY OTHERS)
10	BEMO "40 MIL HT MEMBRANE" (3'x 65' ROLLS)
11	"APPROVED" SEALANT (15 L.F. COVERAGE - TUBES) - (BY OTHERS)
12	4"x 6" BEARING PLATE (AT EACH CLIP)

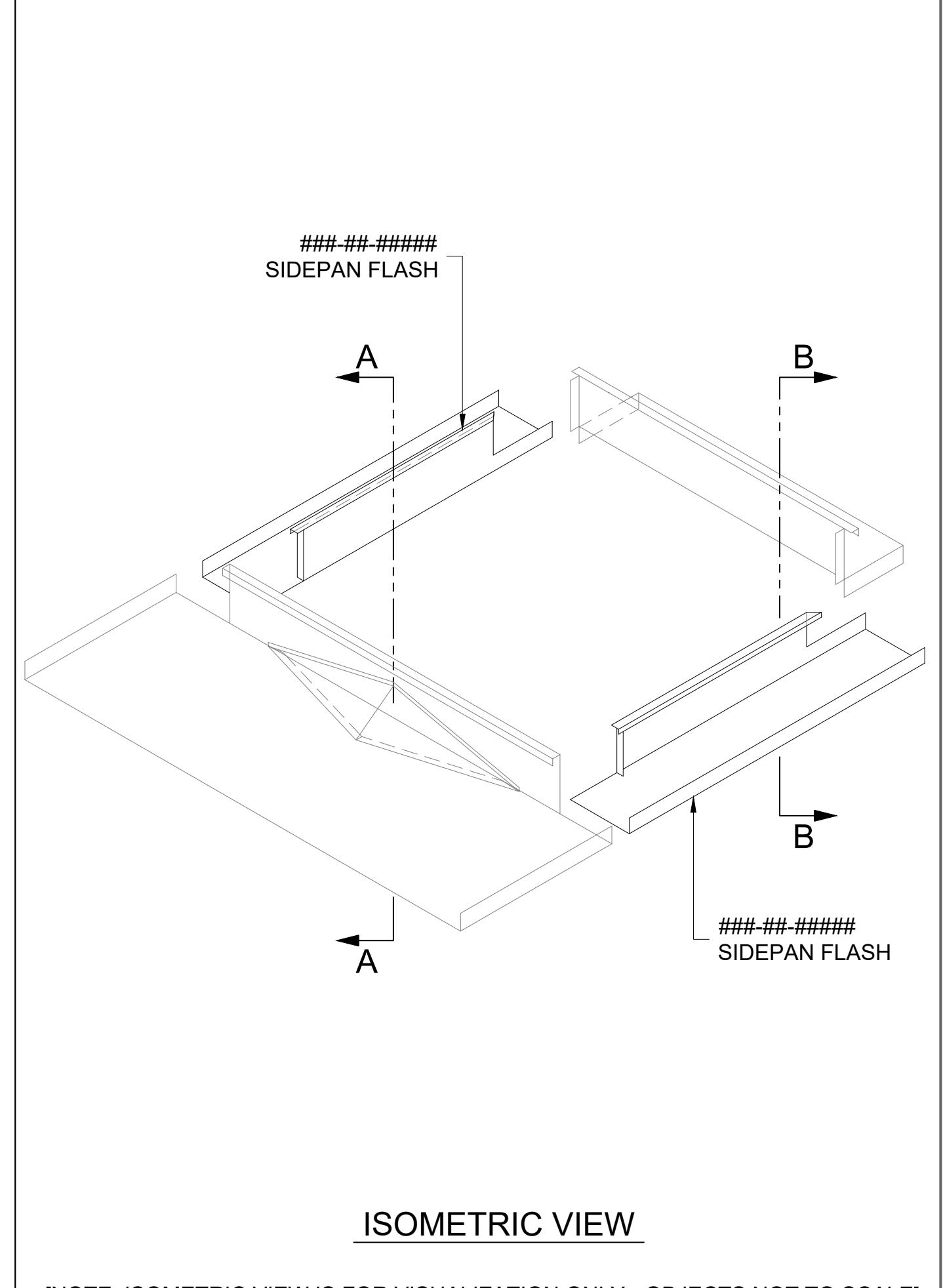

[NOTE: ISOMETRIC VIEW IS FOR VISUALIZATION ONLY - OBJECTS NOT TO SCALE]



BEMO STANDARD DETAILS  
ROOF CURB - SIDEPAN DETAILS

PROJECT ADDRESS \_\_\_\_\_

CUSTOMER NAME \_\_\_\_\_

ARCHITECT NAME \_\_\_\_\_

DRAWN:	D. GOSS	1/25/21
CHECKED:		
PROJECT NUMBER:		
NO.	REVISION / ISSUE	DATE

DWG TITLE  
BEMO STANDARD DETAIL

SCALE	DWG NO.
6" = 1'-0"	D1
REV	